

**AJP MOTOS, S.A.**



**WORKSHOP MANUAL**  
**AJP PR7 ADVENTURE**

**SUPPORT TOOL FOR ASSISTANCE  
MAINTENANCE AND VEHICLE REPAIR**

AJP Motos, SA - Disclaims all liabilities for any errors or omissions present in this manual and reserves the right to make changes that reflect the on-going development. Illustrations and diagrams in this document can differ from the genuine components. The partial or full reproduction of this document is not allowed without written authorization.

1st. Edition (11-2022)

Copyright by  
**AJP Motos, SA**  
Technical Service  
Rua de Santana, 91  
4620-510 Pias, Lousada  
Portugal  
Tel: +351 255 815 122  
Fax: +351 255 815 123  
Website: [www.ajpmotos.com](http://www.ajpmotos.com)

1<sup>st</sup>. Edition (11-2022)

## FOREWORD, TABLE OF CONTENTS

### Foreword

This publication is designed for use by AJP Motos Service Centers to assist authorized personnel in the maintenance and repair of the models covered in this manual. The technical information provided in this manual is a critical complement to operator training and operators should become thoroughly familiar with it. For ease of understanding, diagrams and photographs are provided next to the text.

### Useful tips

To prevent problems and ensure effective service work, observe the following AJP Motos recommendations:

- Before repair, evaluate the customer's description of the problem and ask the appropriate questions to clearly identify problem symptoms;
- Diagnose the problem and identify the causes clearly. This manual provides basic background information that must be supplemented with experience of the operator and/or the training available through the AJP Motos;
- Plan ahead before starting work: gather any spare parts and tools to avoid unnecessary delays;
- Avoid unnecessary disassembly work to get to the part that needs repairing;
- Always read the relevant instructions and follow the disassembly sequence outlined in this manual.

### Recommended shop practices

1. Always replace gaskets, sealing rings and split pins with new ones;
2. When loosening or tightening nuts or bolts, always begin with the bigger ones or from the center. Tighten to the bolts and nuts with the suitable torque;
3. Always mark any parts or positions that might be confused upon assembly;
4. Use genuine AJP Motos parts and the recommended lubricant brands;
5. Technical Bulletins might contain more up-to-date setting data and procedures than this manual. Be sure to read them.

Notes: Unless otherwise specified, data and specifications apply to all models.

## TABLE OF CONTENTS

FOREWORD, TABLE OF CONTENTS .....	4
TABLE OF CONTENTS .....	5
Chapter A. ....	9
Chapter B.....	1
Engine components .....	1
Engine disassembly.....	1
Engine skid Plate.....	2
Cooling System .....	2
Air filter box and injection throttle body .....	3
▪ Loosen the connection of breather tube (3) on the cylinder head (or below air filter box, if present) 3	
Air filter box and injection throttle body .....	4
Exhaust disassembly .....	5
Remove the engine .....	6
Removing the cylinder head cover.....	8
Camshaft disassembly.....	8
Removing the water pump.....	12
Disassembly the water pump.....	12
Cylinder head removal .....	13
Valve removal .....	15
Cylinder removal.....	17
Piston removal .....	18
Flywheel removal.....	18
Clutch cover removal .....	21
Oil filters removal .....	22
Starter motor flange removal .....	25
Starter motor removal.....	25
Gearbox drive shaft removal .....	26
Gear sensor removal .....	28
Crankcase, crankshaft and countershaft disassembly .....	29
Countershaft removal.....	33
Gearbox disassembly.....	33
Crankshaft removal .....	34
Crankshaft components removal .....	35
Chapter C. ....	38
INFORMATION AND SAFETY TIPS .....	39
ENGINE COMPONENTS AND DETAILS.....	40
Cylinder head.....	40

Valve seat refacing .....	40
Valve guide .....	42
Valve guide replacement .....	42
Valve guide replacement .....	44
Valve Spring .....	44
Valve installation .....	45
Rocker arm Inspection .....	45
Camshaft .....	46
Timing chain and gears .....	48
Timing chain tensioners .....	48
Cylinder .....	48
Piston .....	48
Cylinder to piston clearance .....	49
Piston pin .....	49
Piston rings .....	50
Piston ring to cylinder clearance.....	50
Piston ring to groove clearance .....	51
Small end and big end rod clearance.....	52
Big end radial clearance.....	52
Big end radial clearance.....	53
Crankshaft .....	54
Crankshaft straightness.....	54
Small end bushing replacement .....	54
Clutch.....	55
Friction plate to clutch housing clearance .....	55
Clutch spring .....	55
Shifter forks and gears.....	57
Selector drum .....	57
Selector drum to shifter fork pins clearance.....	57
Oil pump disassembly .....	58
<b>Chapter D. ....</b>	<b>59</b>
<b>GENERAL INFORMATION .....</b>	<b>60</b>
Assembly and Lubrication Instructions .....	61
Crankshaft assembly .....	69
Input shaft .....	72
Output shaft.....	73
Crankcase assembly .....	74
Gear sensor installation .....	80
Gear shift control assembly.....	81

- Install the gear shift lever (15) and operate the gearbox manually (9 Nm; 0.9 Kgm; 6.64 ft/lb). .... 84
- Crankshaft gears installation ..... 84
- Countershaft weight/gear installation ..... 84
- Clutch assembly..... 87
- Piston ring installation ..... 89
- Cylinder head gasket selection table ..... 92
- Cylinder head installation ..... 93
- Water pump installation..... 95
- Timing chain tensioner installation ..... 96
- Camshaft installation ..... 97
- Cylinder head cover and spark plug installation..... 99
- Flywheel and flywheel cover installation..... 100
- Sprocket installation ..... 104
- Oil pump and filter cartridge assembly ..... 104
- Right crankcase assembly ..... 105
- Chapter E..... 106**
- GENERAL INFORMATION ..... 107**
- ENGINE ..... 108**
- Cylinder-Head ..... 108
- Crank gear ..... 108
- Transmission..... 108
- Distribution ..... 108
- Base ..... 109
- Lubrication System ..... 109
- Electrical System ..... 109
- Clutch..... 109
- Gear shift control..... 110
- Cooling System ..... 110

# Chapter A.

---

Troubleshooting



In the following tables will be described some problems that may happen as well the solution for them.

	Trouble	Possible causes	Action		
<b>ENGINE</b>	<b>Engine do not start or starts hard</b>	<b>Insufficient compression</b>			
		1. Piston seizure	Replace		
		2. Connecting rod seizure	Replace		
		3. Worn piston rings	Replace		
		4. Worn cylinder head	Replace		
		5. Insufficient tightening of cylinder head	Adjust		
		6. Cylinder head gasket defective	Replace		
		7. Spark plug loose	Adjust		
		8. Incorrect valve clearance	Adjust		
		9. Valve spring weakened or seized	Replace		
10. Valve seizure	Replace				
<b>ENGINE</b>	<b>Engine do not start or starts hard</b>	<b>Weak or non-existent spark</b>			
		1. Spark plug defective	Replace		
		2. Spark plug dirty or wet	Clean		
		3. Excessive spark plug electrode gap	Adjust		
		4. Ignition coil or ignition cable defective	Replace		
		5. Open/short circuit in high-voltage cables	Check		
		6. ECU defective	Replace		
		7. Right switch defective	Replace		
		<b>ENGINE</b>	<b>Engine do not start or starts hard</b>	<b>Fuel pump does not work</b>	
				1. Injection fuse burnt	Replace
2. Injection relay defective	Replace				
3. Incorrect battery voltage	Replace				
4. ECU defective	Replace				
5. Fuel pump malfunction	Replace				
<b>ENGINE</b>	<b>Engine excessively noisy</b>			<b>The noise seems to come from the piston</b>	
				1. Excessive clearance between piston and cylinder	Replace

	2. Piston or cylinder worn	Replace
	3. Excessive accumulation of carbon deposits in combustion chamber or piston crown	Clean
	4. Rocker arm worn	Replace
	5. Incorrect valve clearance	Adjust
	6. Valve spring weakened or seized	Replace
	7. Distribution chain worn	Replace
	8. Incorrect distribution chain tension	Adjust
	<b>The noise seems to come from the crankshaft</b>	
	<hr/>	
	1. Bearings worn	Replace
	2. High radial or axial clearance on connecting rod	Replace
	3. Crankshaft gear damaged	Replace
	4. Crankshaft loose	Check
	<b>The noise seems to come from the crankshaft</b>	
	<hr/>	
	1. Bearings worn	Replace
	2. High radial or axial clearance on connecting rod	Replace
	3. Crankshaft gear damaged	Replace
	4. Crankshaft loose	Check
	<b>The noise seems to come from the clutch</b>	
	<hr/>	
	1. Friction clutch plates worn	Replace
	2. Excessive play between clutch housing and drive plates	Replace
<b>Engine turns off easily</b>	1. Spark plug encrusted	Clean
	2. ECU defective	Replace
	3. Low idle	Adjust
<b>The noise seems to come from the secondary drive chain</b>	1. Drive chain stretched or incorrectly adjusted	Adjust/ Replace
	2. Gearbox output pinion and crown worn	Replace

<b>Clutch splits</b>	1. Load spring weakened	Replace
	2. Clutch friction plates worn	Replace
<b>Clutch resist</b>	1. Load spring defective	Replace
	2. Clutch friction plates warped	Replace
<b>Gears do not engage</b>	1. Shift forks bent or seized	Replace
	2. Gearshift pawl worn	Replace
	3. Forks control pins damaged	Replace
<b>Gears disengage</b>	1. Worn sliding gear clutches	Replace
	2. Worn gear splines	Replace
	3. Worn gear coupling seats	Replace
	4. Gear shift cam worn	Replace
	5. Forks control pins damaged	Replace
<b>Shift pedal do not return to position</b>	1. Shift return spring weakened or broken	Replace
	2. Shift forks worn	Replace
<b>Engine has no or insufficient performance</b>	1. Air filter dirty	Clean
	2. Poor fuel quality	Replace
	3. Breather join loose	Adjust
	4. Excessive spark plug electrode gap	Adjust
	5. Insufficient compression	Check
	6. Incorrect valve clearance	Adjust
	7. Valve guide or seat spring defective	Replace
	8. Valve spring weakened or seized	Replace
<b>Engine overheats</b>	1. Excessive accumulation of carbon deposits in combustion chamber or piston crown	Clean
	2. Not enough or not recommended engine oil	Refill/ Replace
	3. Radiator dirty	Clean
	4. Cylinder head gasket defective	Replace

	5. Clutch splits	Adjust
	6. Cooling fan motor defective	Replace thermostat

CHASSIS	Trouble	Possible causes	Action
	Hard steering	1. Tire low pressure	Check
		2. Steering bearing or stem too tight	Adjust
		3. Steering stem bent	Replace
		4. Steering bearings worn or seized	Replace
	Steering vibration	1. Front fork legs bent	Replace
		2. Front wheel axle bent	Replace
		3. Frame bent	Replace
		4. Front wheel rim damaged	Replace
		5. Front wheel bearings worn	Replace
Hard shock absorption	1. Excessive oil quantity in front fork legs	Adjust	
	2. High fork oil viscosity	Replace	
	3. Excessive tire pressure	Adjust	
	4. Incorrect rear shock absorber setup	Adjust	
Soft shock absorption	1. Insufficient oil quantity in front fork legs	Refill	
	2. Low fork oil viscosity	Replace	
	3. Fork springs weakened	Replace	
	4. Rear shock absorber spring weakened	Replace	
	5. Incorrect rear shock absorber setup	Adjust	
Wheels vibration	1. Wheel rim damaged	Replace	
	2. Wheel bearings worn	Replace	
	3. Incorrect spoke tension	Adjust	
	4. Wheel axle nut loose	Adjust	
	5. Swing arm bearings worn	Replace	
	6. Drive chain incorrectly adjusted	Adjust	

	7. Wheel improperly balanced	Adjust
<b>Rear suspension noisy</b>	1. Rod spacers or bearings worn	Replace
	2. Shock spherical joints worn	Replace
	3. Shock absorber defective	Replace
<b>Insufficient brake</b>	1. Air in brake system circuit	Replace
	2. Water in brake system circuit	Replace
	3. Insufficient quantity of fluid in reservoir	Check/ Refill
	4. Brake pads or disk worn	Replace
	5. Brake disk damaged	Replace
	6. Wrong brake pedal setup	Adjust
<b>Excessive exhaust noise</b>	1. Exhaust system broken	Replace
	2. Exhaust system leak	Check

# Chapter B.

---

## Engine Components and Disassembly Process

## Engine components

1. Cylinder head cover
2. Cylinder head
3. Timing chain tensioner
4. Cylinder
5. Starter motor
6. Head lubrication pipes
7. Oil pump
8. Generator cover
9. Oil filter cover
10. Water pump
11. Clutch cover

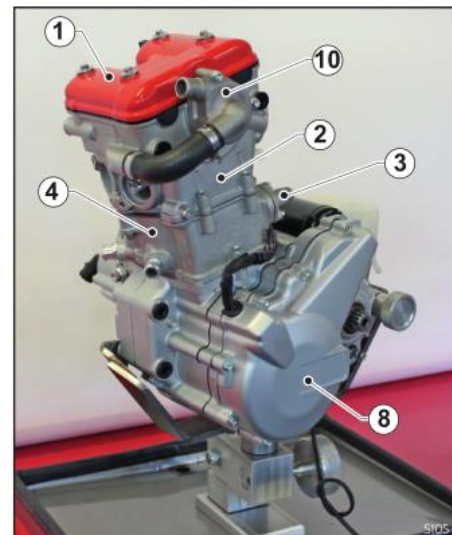
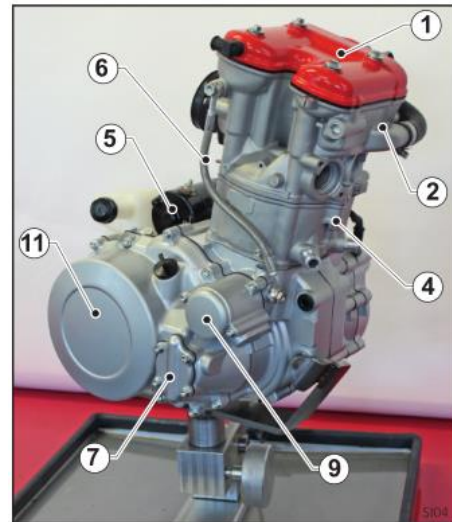

## Engine disassembly

Before removing the engine from the frame, it is recommended to wash and clean the motorcycle completely. This includes particularly the area of wiring and electrical components between inner frames above the engine head in order to prevent any dirt from falling into the engine during installation.

The coolant must be completely drained, as well as the used oil, before removing the engine

## Engine disassembly from motorcycle:

Carry out the necessary procedures for disassembly with the engine cold and in the sequence shown below

### Engine skid Plate

- Remove engine skid plate (1)



### Cooling System

- Remove all the liquid from the refrigeration circuit, collecting it in a suitable reservoir for later recycling.
- The drain bolt on the right side of the cylinder must be removed and the radiator cap removed as well. Then the two water pipes in the cylinder to the radiator can be detached, as well as the pipe that connects the water pump to the thermostat and by-pass tee on the left radiator
- The expansion reservoir (2) can be unscrewed on the left engine support (3) to allow all the antifreeze liquid to drain out. In this way it is possible to remove practically all the liquid existing in the cooling circuit

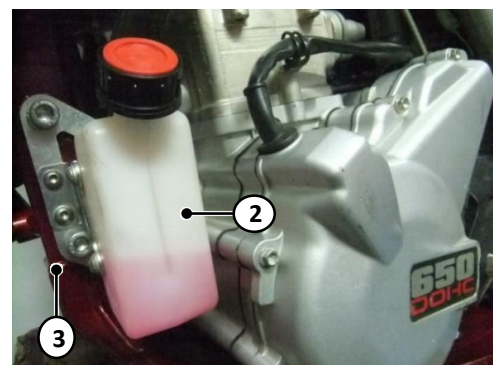
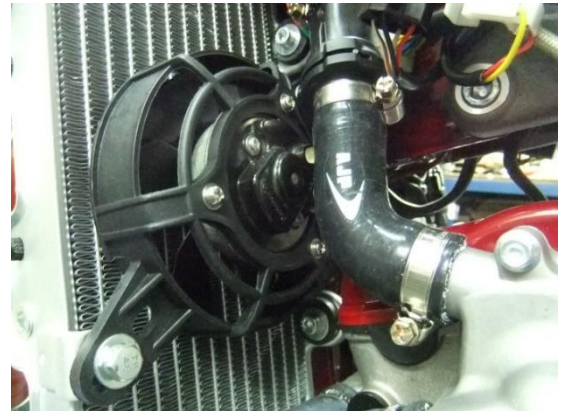

It is recommended that the engine oil be drained before removing engine from the motorcycle frame, this will facilitate it disassembly.

Note: There are two plugs that must be removed to drain all the engine oil. The small plug in the left crankcase is unscrewed with a 12MM socket or spline wrench and drains the oil coming from the crankshaft/connection rod lubrication and distribution in the cylinder head located at the bottom of the crankcases. The large plug in the right crankcase, drains the existing oil in the gearbox and clutch compartment and it is unscrewed with a 10MM wrench.



Place a reservoir under the engine to collect all the engine used oil.

## Air filter box and injection throttle body

- Remove the seat and side covers
  - Loosen the breathe tube next to the cap (1) and in guide on the filter box. Unscrew the two screws that fix fuel tank inlet pipe with the cap on the air filter box
  - Slightly unscrew the clamp on the connection pipe to the tank and turn the pipe/cap (2) moving it to the side without removing it from the tank to avoid fuel leakage if the tank is to full
  - Posteriorly, in the assembly, do not forget that both clamps must be turn to back and tightened by right side
- 
- Loosen the connection of breather tube (3) on the cylinder head (or below air filter box, if present)
  - Loosen the breather tube on the engine
  - Unscrew the four air filter box fixing screws on the inner frames. Then lift the box at the front to undock it from the neck and separate it from the injection body
  - Remove the three screw on the intake manifold and tie the body together with the manifold with a wire or a string so they do not fall down



Note: To remove the engine it isn't necessary disassembly the injection body, unless cleaning operations and sensors maintenance are necessary. Therefore, the assembly can be kept tied with a wire around the inner frames, so that it does not fall down and difficult the removal or installation of the engine.

## Air filter box and injection throttle body

- Disengage the stator connector, pick-up and then remove the wires coming from the engine between left frame beam (1) and the throttle body.
- Disconnect the connector on the cylinder head temperature sensor and the neutral contact.
- Loosen the starter and ground cables terminals on the engine (2).
- Remove the spark plug cap (3)
- Remove the Lambda sensor on the exhaust, which can be unscrewed with a 22MM spanner, or disconnect the connectors

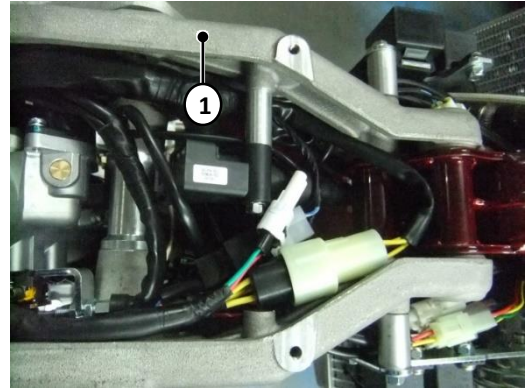

## Exhaust disassembly

**Note:** To remove the bends form exhaust pipe, it is recommended loose the radiators from the lower mounting to the frame to facilitate the disassembly of the screws on the exhaust pipe flanges.

- Remove the exhaust muffler
- Remove the spring and unscrew the fastening screw of the clamp on the fuel tank support. Sometimes, to facilitate the disassembly of the muffler lubrication spray can be applied in the area where the muffler joins the exhaust pipe
- To remove the exhaust pipe, you must first remove the fixing screw on the left frame beam, releasing the brake pedal. Remove the spring on the exhaust pipe and then dismount the right bend on the exhaust pipe flange on the engine

**Note:** If you are removing the complete exhaust (although it is recommended disassembly first the muffler), you must turn the bend on the right side until you can pass the pipes through the frame tube to be able to remove the complete exhaust pipe (with the muffler included).



## Remove the engine

- Release the brake pedal spring (1) on the support tightened on the engine
- Remove the sprocket cover (2)
- Release the hydraulic clutch pusher cylinder and remove its base/flange of fastening on the engine

Note: While the hydraulic pusher cylinder stay away from the engine never actuate the clutch lever. If you do it, you can irreparably damage the hydraulic clutch pusher cylinder

- Remove the protective metallic arch on the clutch pump over the chain/sprocket
- Remove the retainer circlip, dismount the sprocket on the motor shaft and remove the chain to remove the front sprocket (3)

Note: While the rear wheel stay removed with the chain still installed on the front sprocket, you mustn't turn on the key and press the starter button with the engine case in gear, as the transmission chain will be piggybacked underneath of the sprocket, which could damage the arch/metallic protection as well as the support flange of the hydraulic clutch pusher cylinder or even brake the crankcase of the engine

- Remove the engine front supports on the frame (4)
- Remove the screw on the engine lower fastening on the steel frame
- Unscrew the screw on the lower fastening of the right beam to give some clearance between the arm and the engine (a 15MM sheet washer can be introduced between each beam and the frame)
- Remove the engine/swing arm shaft by right side
- Pull the swing arm back a little, but without the washer get out of the place until it is possible to remove the engine
- Raise the engine until dismount it from the tabs on the lower fastening of the steel frame

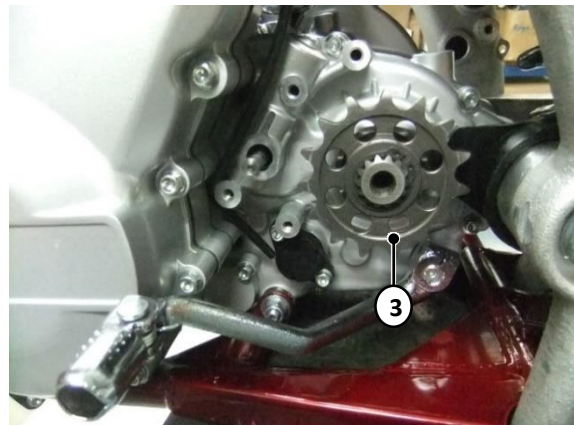
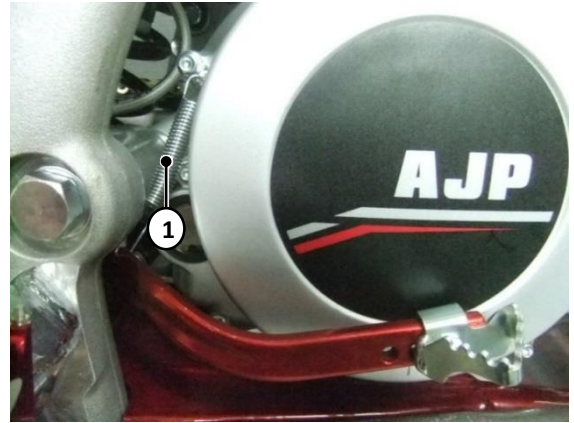

- Remove the engine from the frame on the left side of the motorcycle
- Reinsert the shaft or a steel rod into the beams hole to keep the arm and rear wheel assembly with the chassis, so that the motorcycle can be handled if necessary while the engine remains removed



## Engine disassembly:

### Removing the cylinder head cover

- Remove the four fixing screws (1).  8mm
- Remove the head cover (2) and gaskets.

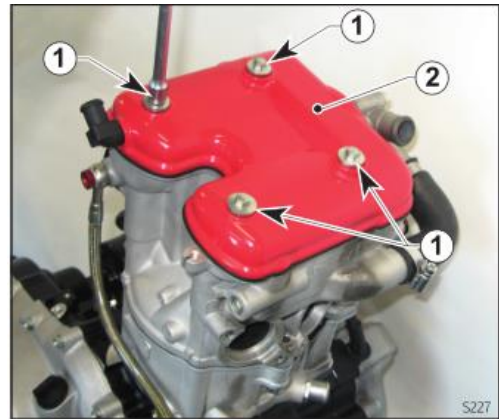

### Camshaft disassembly

- Remove the cylinder head cover.
- Unscrew the eleven screws (1).  8mm
- Remove the generator cover (2).
- Remove the complete generator (3) and starter motor reduction gear (4) with the respective gasket.

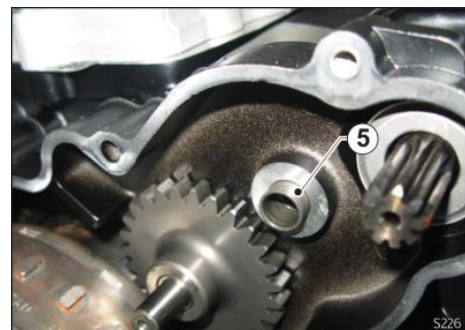
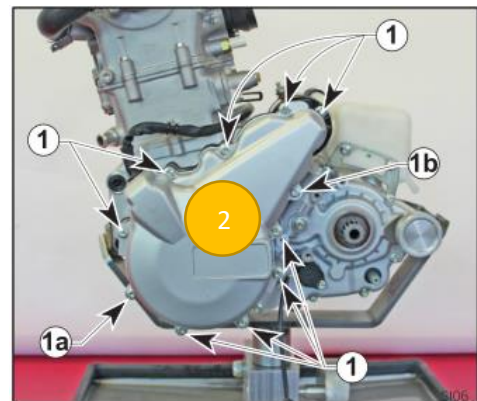

Screws 1a and 1b are longer (65mm) and must be placed in the same position.

Pay attention to the bush (5). Remove it from the flange (6) and insert in the pin (7) of the starter motor gear.

WARNING

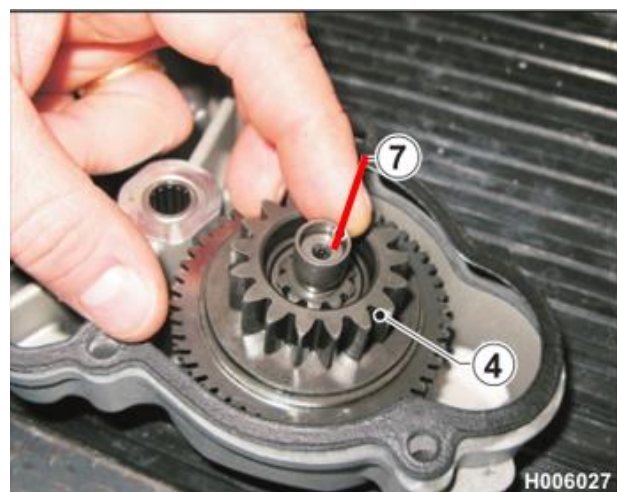
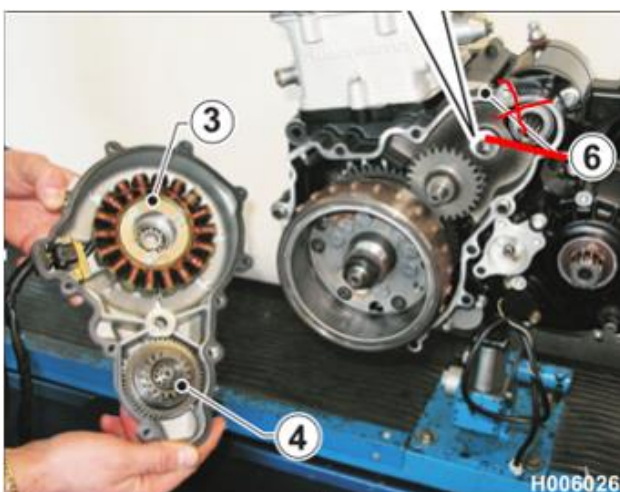

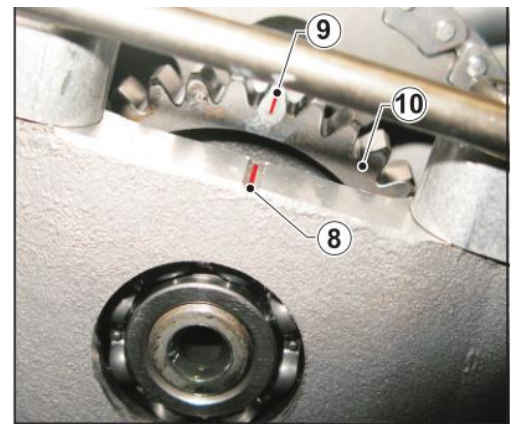
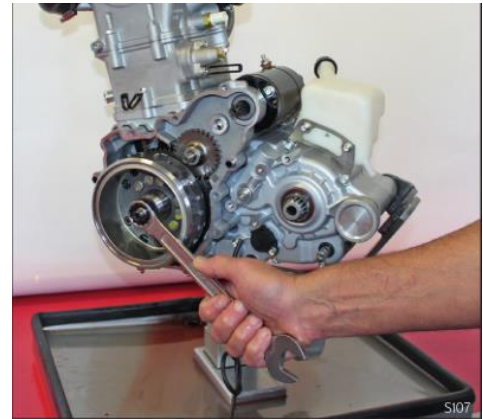

- Position the piston at T.D.C. at the end of compression phase. In this condition the notch (8) located on the cylinder head should be aligned with the notch (9) on the camshaft gear (10).  24mm

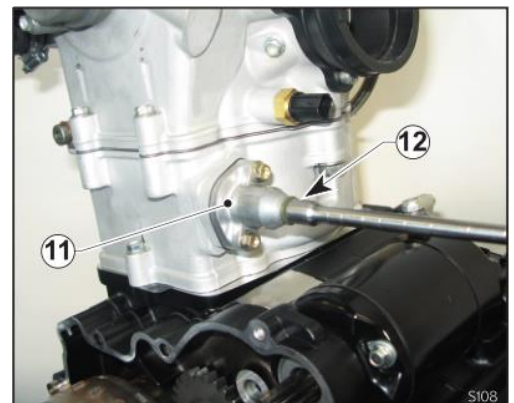

- Remove the timing chain tensioner (11) as follows:
  - Unscrew the screw (12).  8mm



- Release the spring tension by turning clockwise the screw (13) until it stops at the limit position. 
- Unscrew the two screws (14).  8mm
- Remove the timing chain tensioner (11).

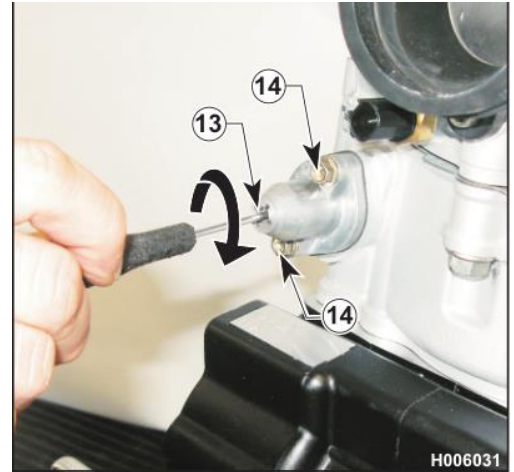

- Unscrew the eight screws (15) securing the bearing brackets (16) of the camshafts (17).  5 mm

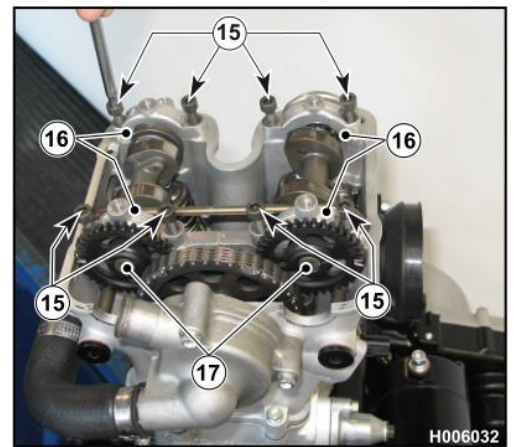

- Remove the bearing brackets (16) by tightening manually one of screws (15) in the threaded holes (18).

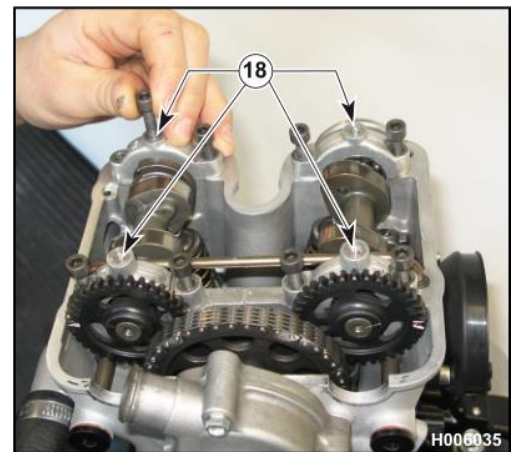



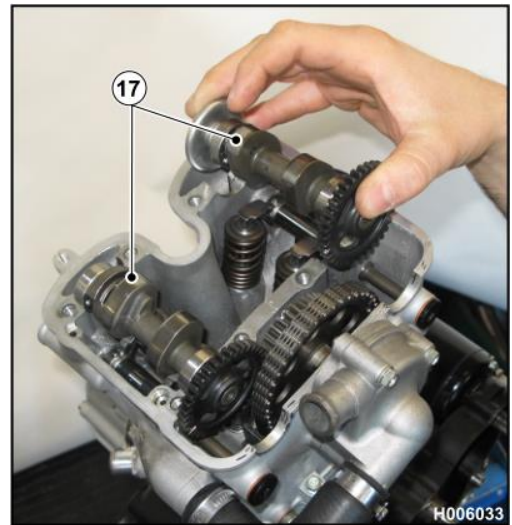
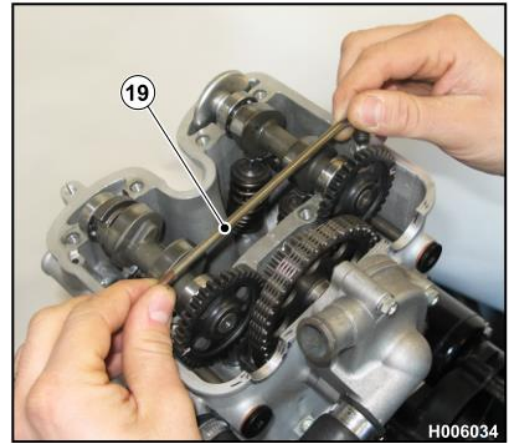

- Remove the lubrication tubes (19) and the camshaft (17).



## Removing the water pump

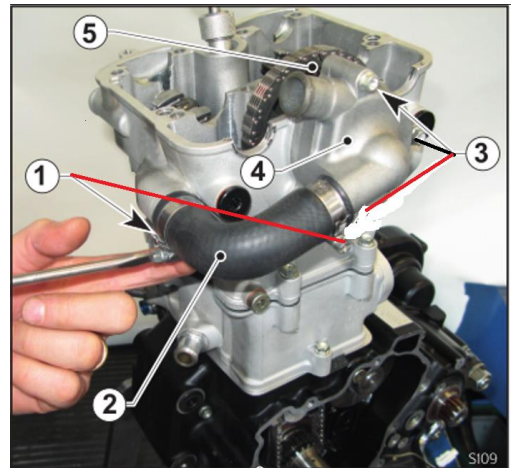

- Disassemble the cylinder head cover, camshaft and timing chain tensioner as specified previously.
- Loosen the pipe clamps (1) of the water pump tube (2) and remove it. 
- Unscrew the three screws (3) holding the water pump (4) on the cylinder head.  8mm
- Remove the water pump body and the timing gear (5).



### WARNING

When assembling, check the wear condition of the O-ring (9). If damaged, replace the O-ring.

## Disassembly the water pump

- Loosen the screw (8) to open the water pump body.  8mm
- Unscrew the nut (10) to remove the impeller (11).  8mm
- Remove the bolt (12) to replace the bearing (13) and the seal (14).

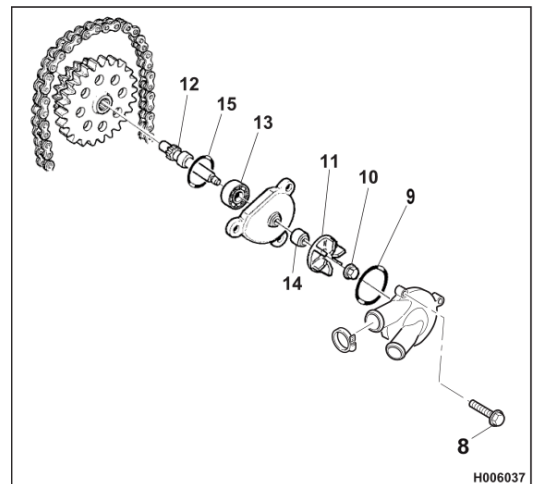

## Cylinder head removal

- Remove head cover, camshafts, chain tensioner and water pump as described in the relevant paragraph.
- Remove the two M6 screws (1) on the left side and the M8 nuts (2) located up front and at the rear under the head.

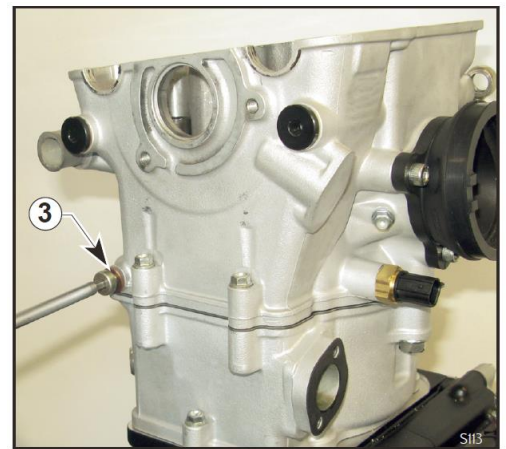
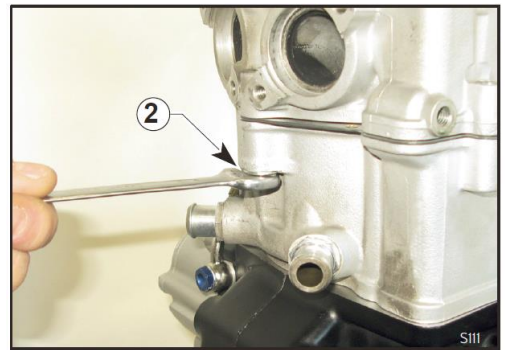
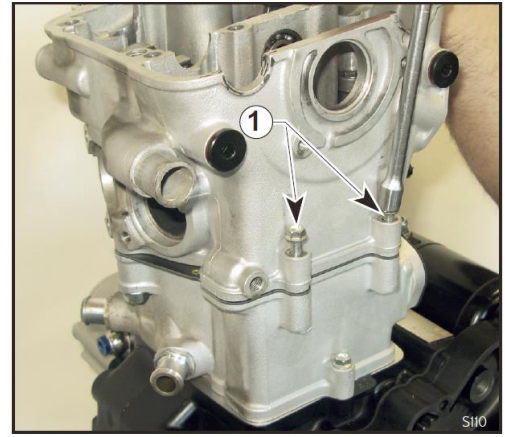
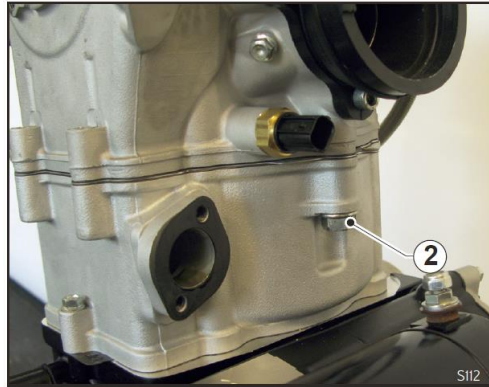

- Use a 5 mm Allen wrench to loosen the screw (3) and remove the chain slider (4).

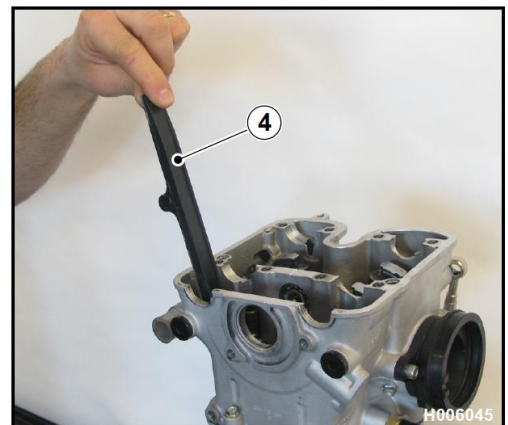

- Remove the four stud bolts (5) inside cylinder head (6) (10 mm Allen wrench - 0.39 in.) in a cross pattern.
- Remove the cylinder head and its gasket (7).

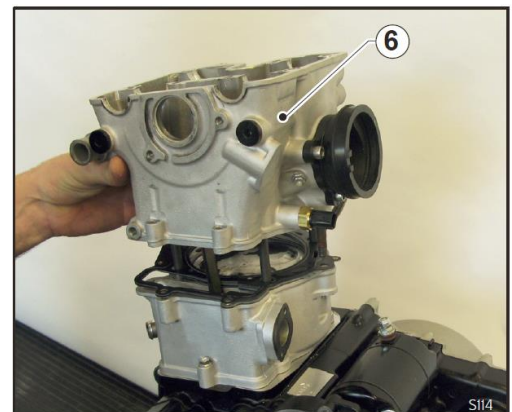
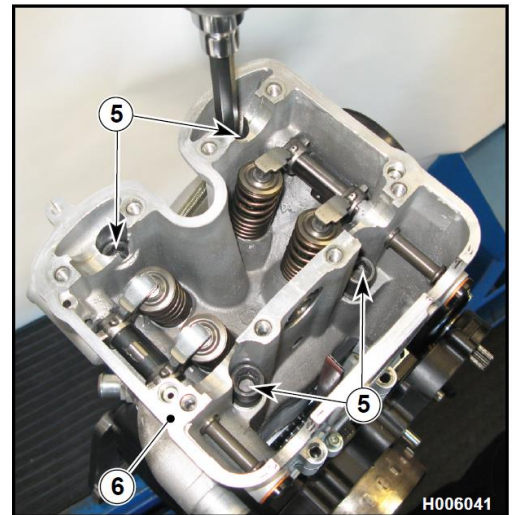
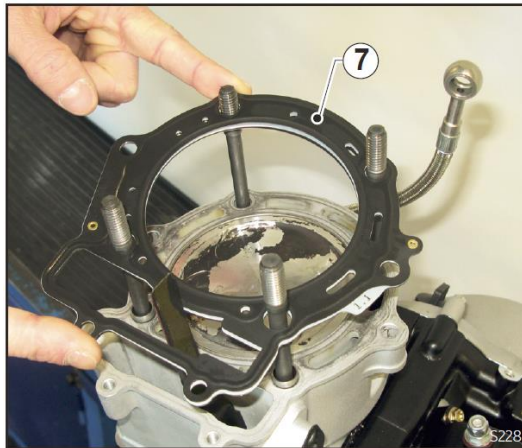

## Valve removal

- Remove the cylinder head as described in the relevant paragraph.
- Remove the rocker arm spring spacers (1) using a hook.
- Remove the rocker arm shaft screws (2) (6 mm Allen wrench) and then remove rocker arm shafts (3) and rocker arms (4).

WARNING

Mark the valves and their components so as to refit in their original positions on assembly.

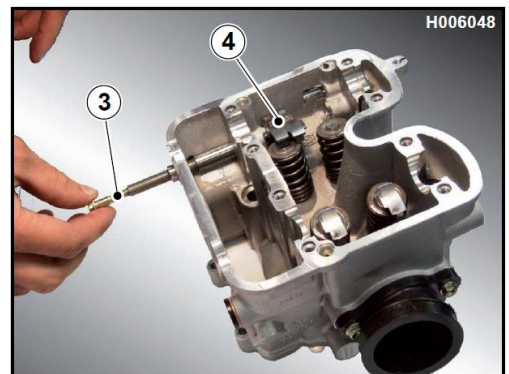
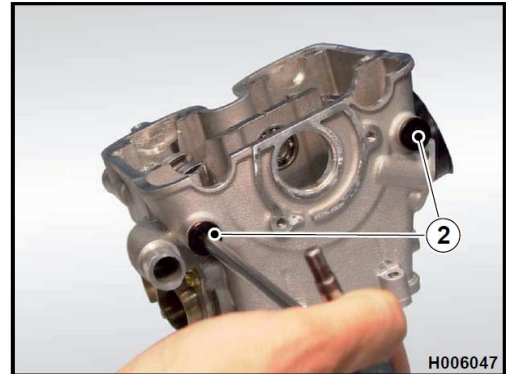
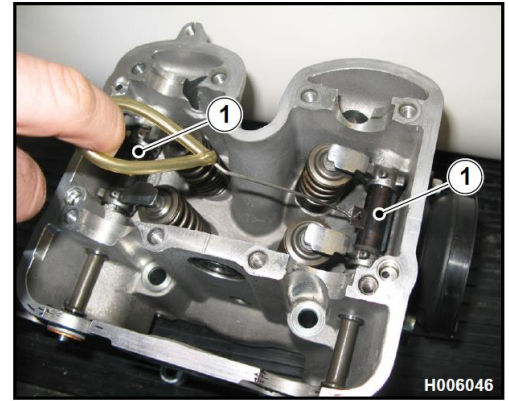
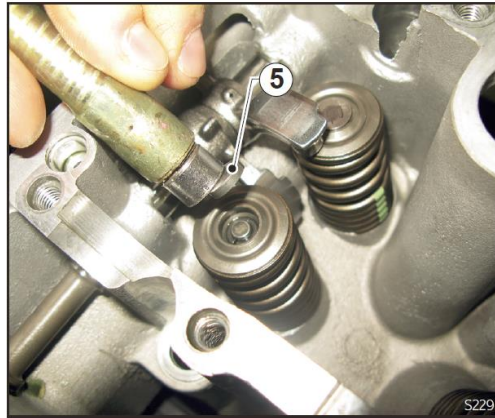

- Use a valve spring compressor (6) to compress the valve springs. Be careful not to damage the mating surfaces that contact the gasket or those of the combustion chamber.
- Make sure the valve spring compressor is aligned straight on the spring, or you might bend the valve stem. Do not compress the springs too much or they will weaken.

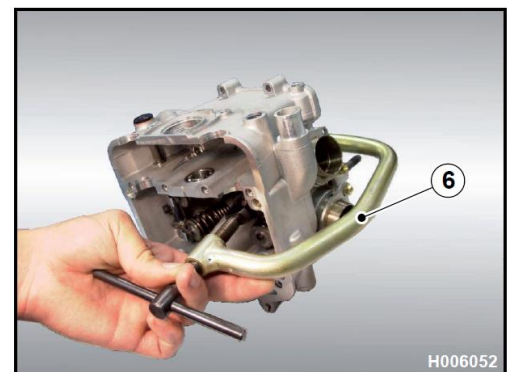

- Mark all parts to ensure that they are refitted in their original positions on assembly. If the valve collets (7) have caused burrs on the valve stems, remove them before removing the valves.

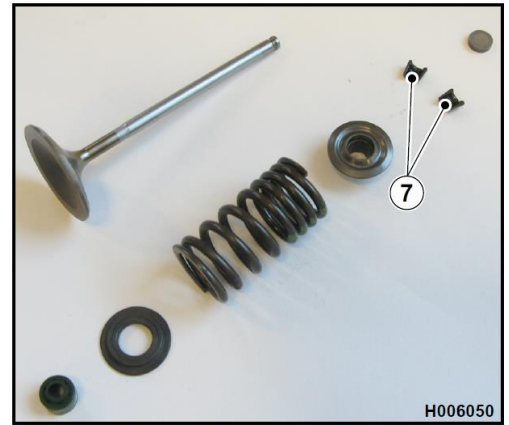

- Remove the seals (8) from the valve guides.
- Remember that seals must be replaced on assembly.

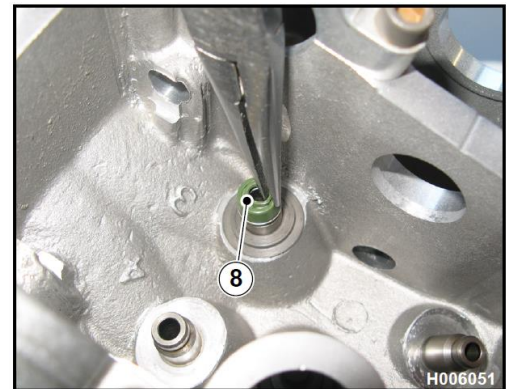

## Cylinder removal

- Remove the head as described in the relevant paragraph.
- Loosen the cylinder retaining screw (1) using an 8 mm (0.31 in.) wrench.

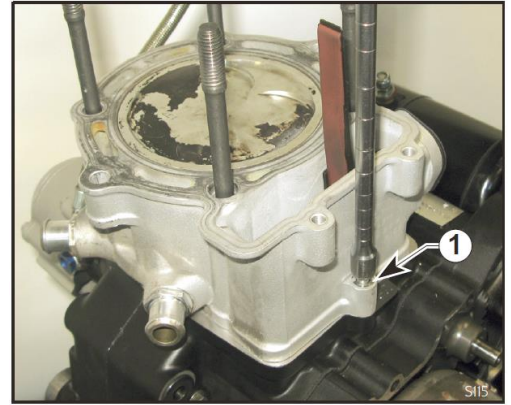

- Remove the centering bushings (2).

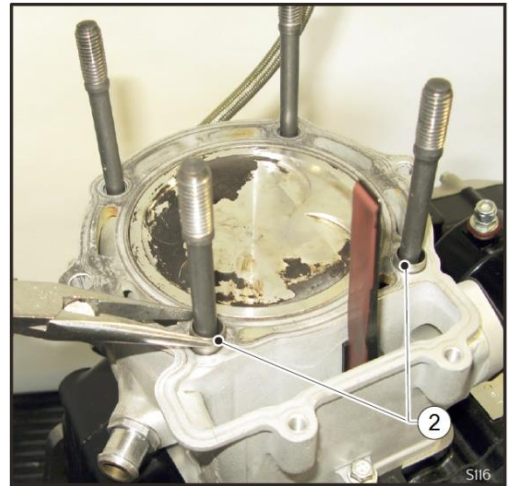

- Remove the cylinder (3) with its gasket (4).

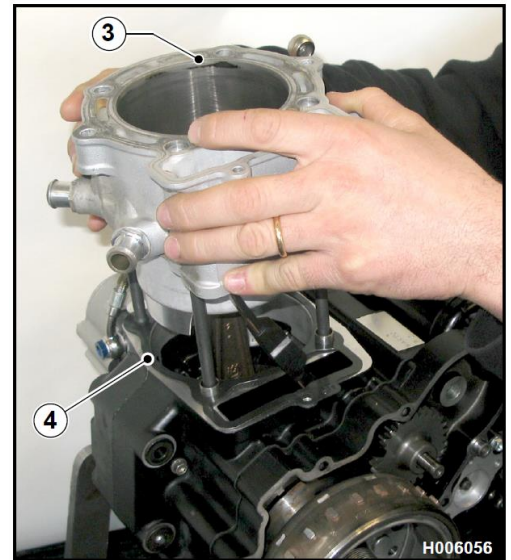

## Piston removal

- Remove the piston pin retaining rings (1), slide out the piston pin (2) and remove the piston (3).

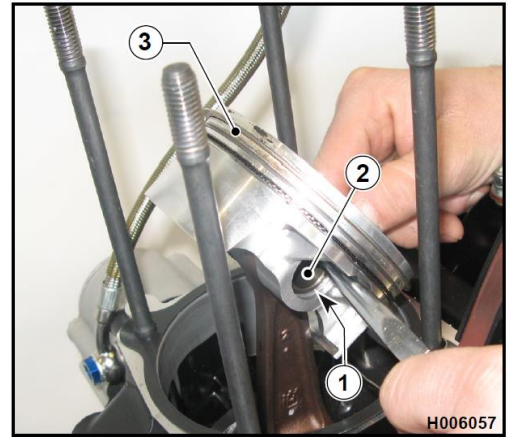

## Flywheel removal

- Remove the generator cover as described in the relevant paragraph.
- Loosen the nut (1) and washer (2) securing the rotor (3) (24 mm wrench - 0.94 in.).

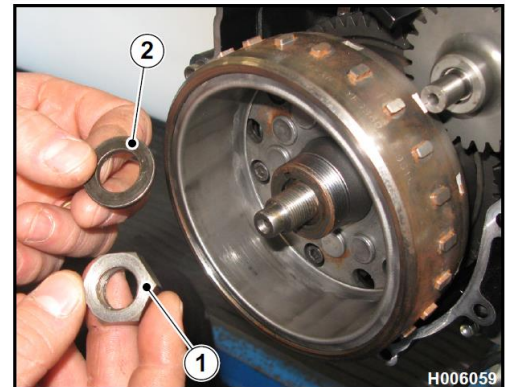
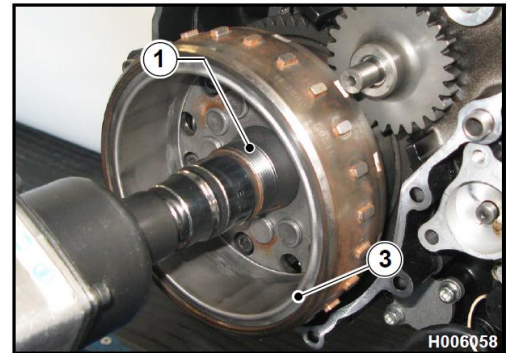

- Fit guard (4) to the crankshaft.

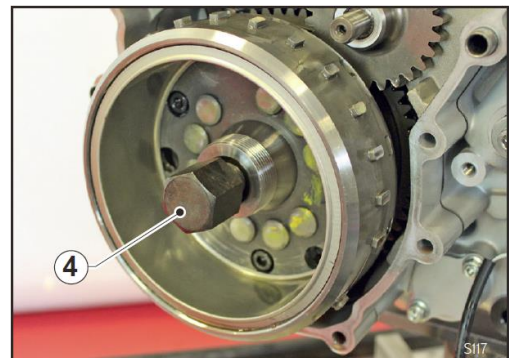



- Remove the rotor (3) using the puller (5).

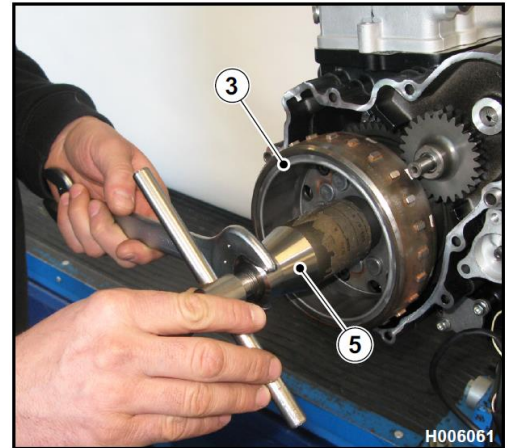

- Remove the flywheel (3) together with freewheel and idler gear (6).

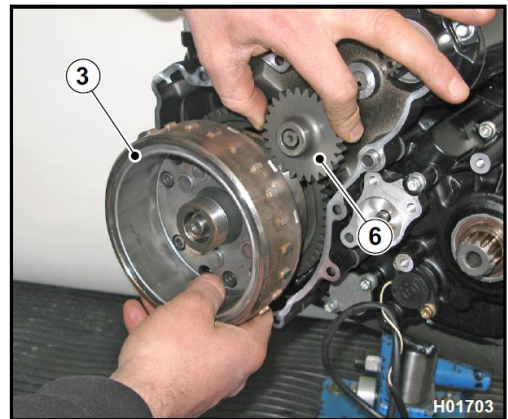

- Remove the roller cage (7) and the washer (8);

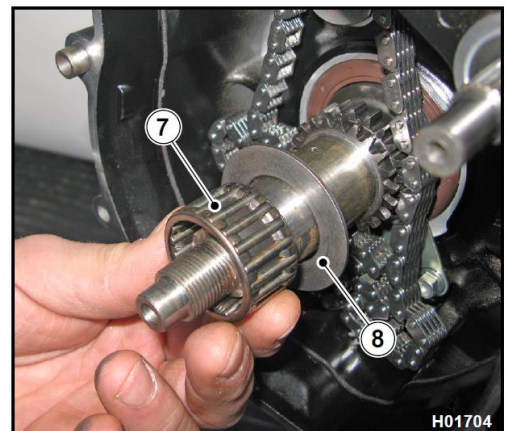

- Heat and remove the screws (9) (5 mm - 0.19 in. Allen screws) and check the freewheel status: the rollers courses of action must not be worn or damaged.
- Ensure that all gears are in good condition.

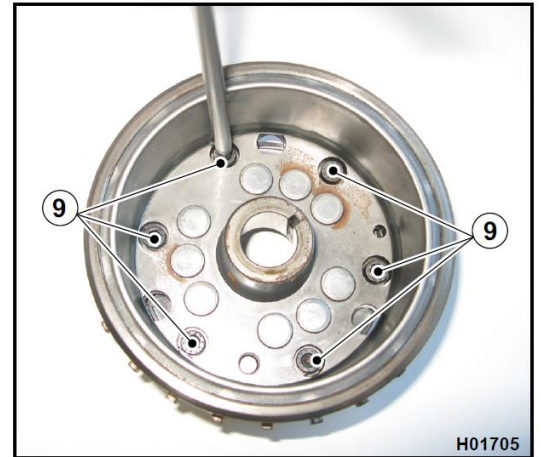

## Clutch cover removal

**WARNING**

Before removing the clutch cover, drain engine oil as described in the relevant Section.

- Remove the eleven M6x30 screws (1) and the two M6x40 screws (2) M6x40 which fix the cover (3); remove the cover (3) with the related seal (4).

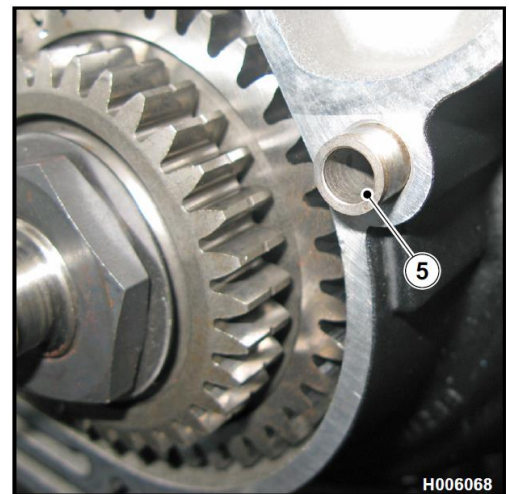
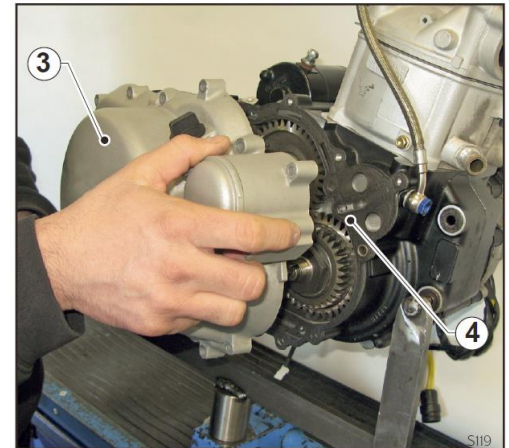
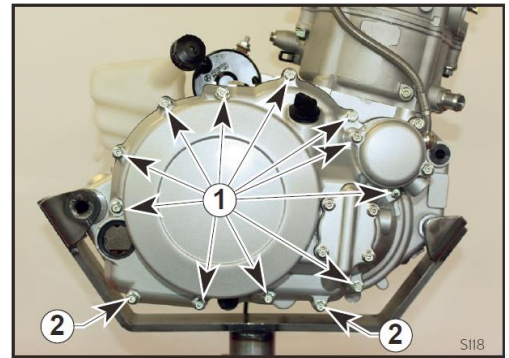

- Remove the bushings (5).

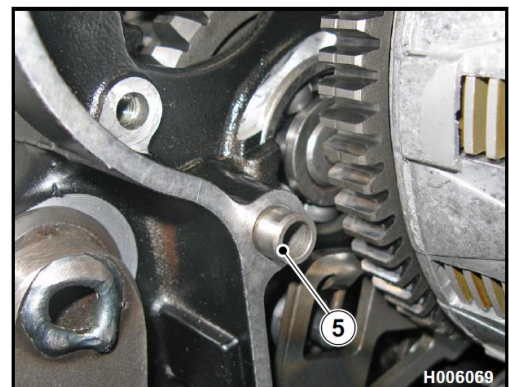

## Oil filters removal

### Mesh filter

- Remove the clutch cover as described in the relevant paragraph.
- Extract mesh filter (1) from its seat using long nose pliers.
- Wash filter with petrol and blow with compressed air; refit filter with the short pin facing outside.

Reassemble all parts, in the reverse order compared to disassembly.

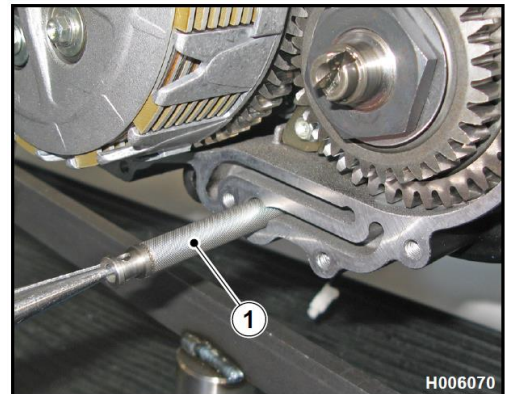

### Cartridge filter

- Loosen the screws (2) (8 mm wrench) and remove cover (3), spring (4) and filter (5).
- Replace the filter (5) and make sure to fit it with the rubber end (6) facing into the engine.
- Check the O-ring (7) and replace it if damaged.

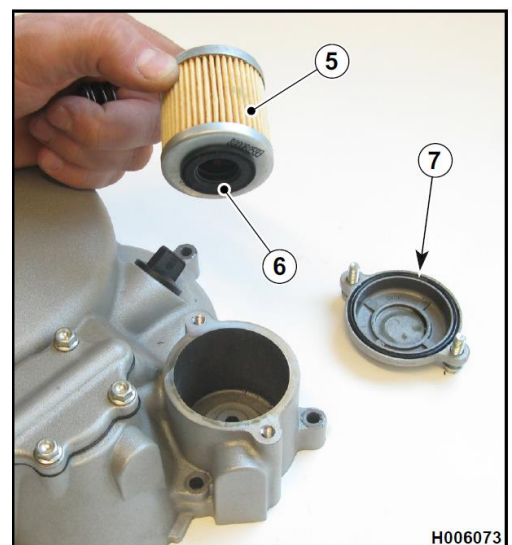
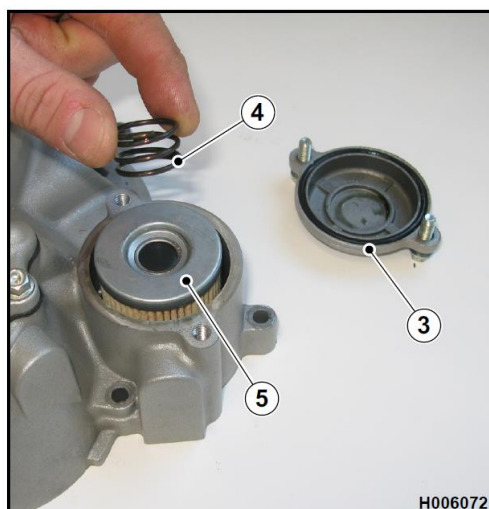
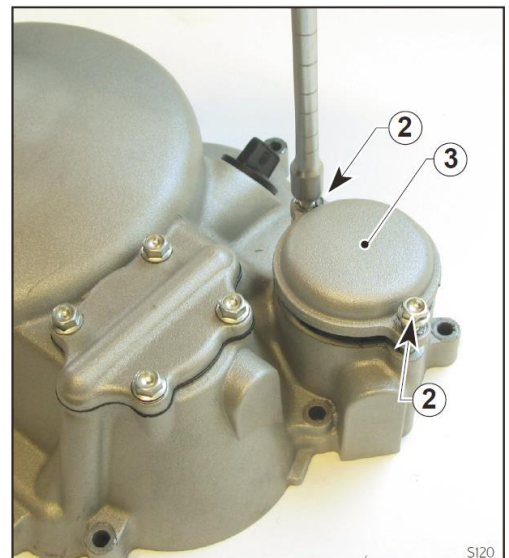

### Mesh filters on flywheel side

- Loosen the screws (8) and remove cover (9).
- Extract the two mesh filters (10), wash them with petrol and blow with compressed air.
- Reassemble all parts, in the reverse order compared to disassembly. Check cover seal for damage.

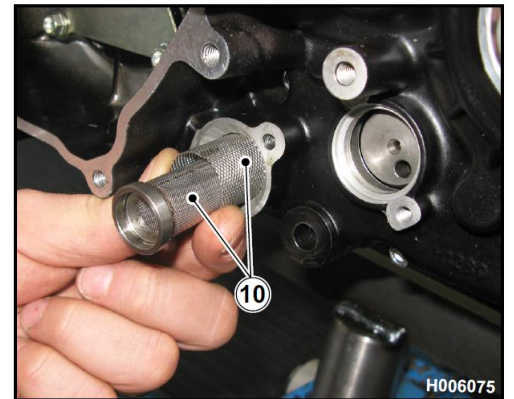
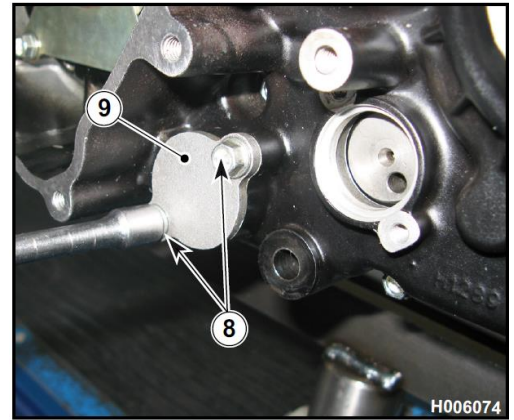

### Clutch disassembly

- Remove the clutch cover as described in the relevant paragraph.
- Using an 8 mm (0.31 in.) wrench, unscrew the six screws (1) securing the clutch springs.
- Remove springs, pressure plate (2) with actuator (3) bearing (4) and shim.

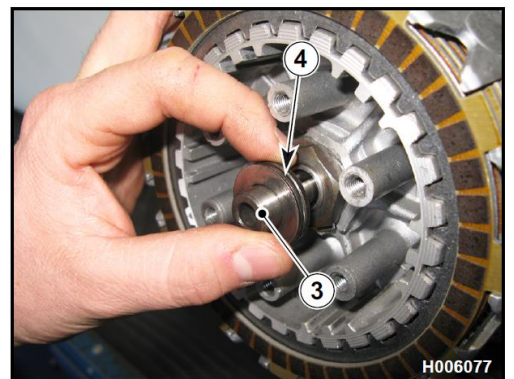
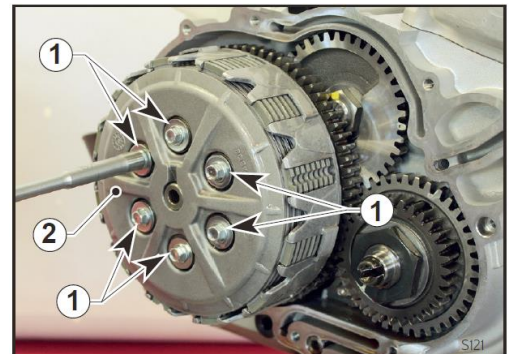

- Remove the splined spacer (9).

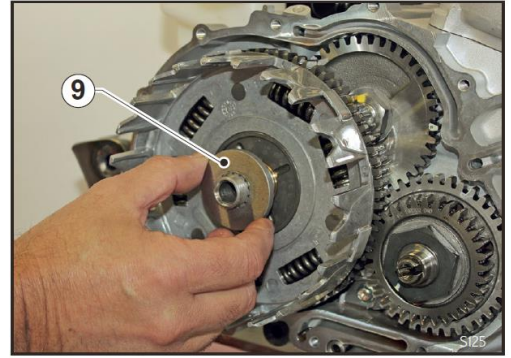

- Remove clutch housing (10) and clutch pushrod (11).

**WARNING**

Clutch housing and drive gear (12) must always be replaced as a set.

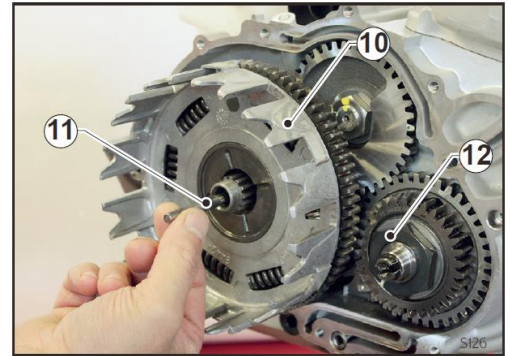

- Remove the compass (13) with the related shim (14).

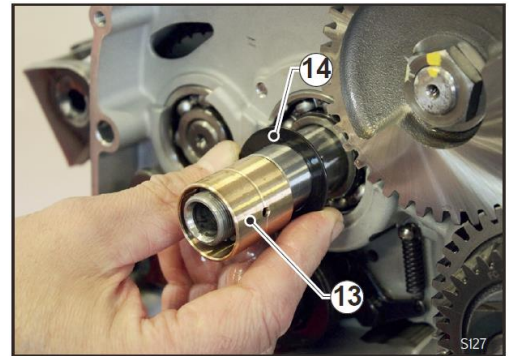

## Starter motor flange removal

Remove the ignition cover together with starter drive gear as described in the relevant paragraph.

- Remove the flywheel with its drive gear;
- Remove the flange (1) (tapping gently on the projections with a rubber hammer) with its gasket (2), the second drive gear (3) and the centring bushings (4).
- To remove the drive unit (3), remove snap ring (5), washer (6) and seal (7), and then slide off the drive unit (3) from the opposite end.

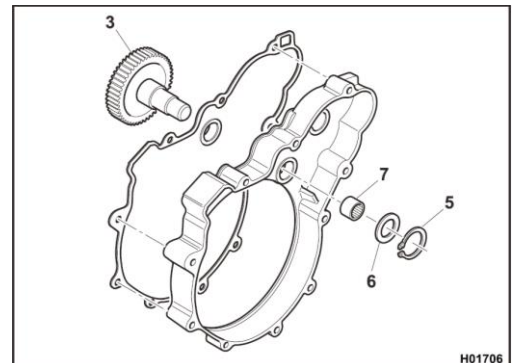
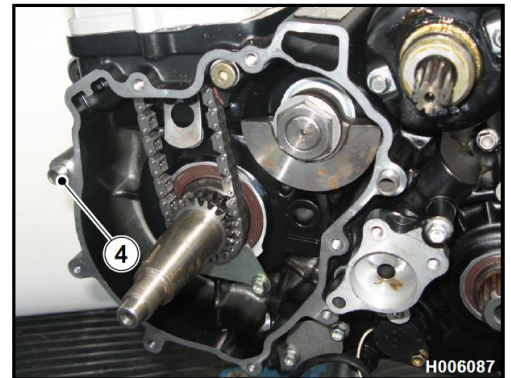
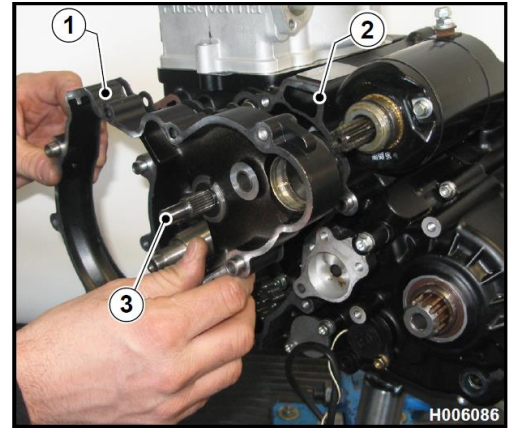

## Starter motor removal

- Remove the starter motor flange as described in the relevant paragraph.
- Loosen the two screws (1) and remove the starter motor (2).

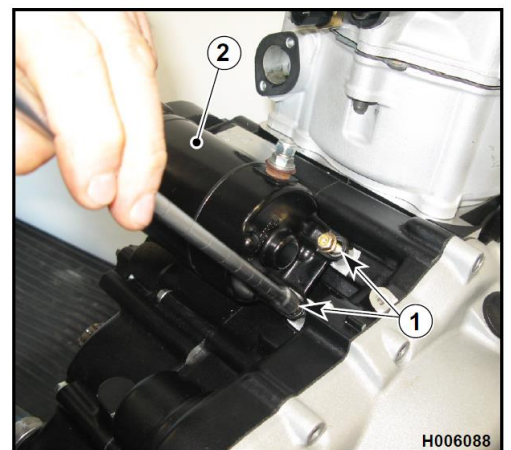

## Gearbox drive shaft removal

- Pull out the selector shaft (1).

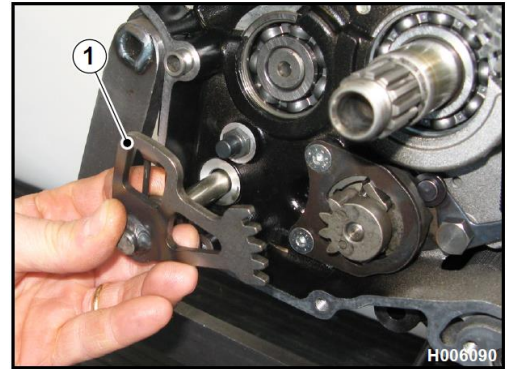

- Loosen the two 4 mm (0.157 in.) socket head screws (2) and remove plate (3) and selector sector gear (4).

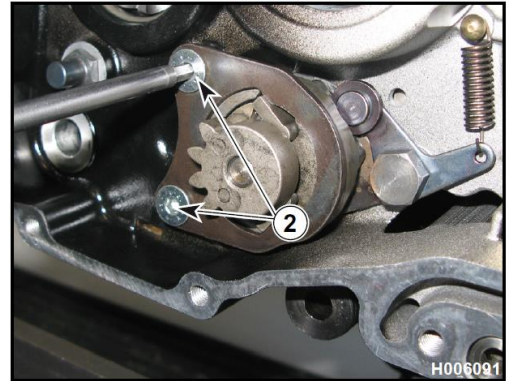
**WARNING**

Be careful not to lose sector gear assembly components.

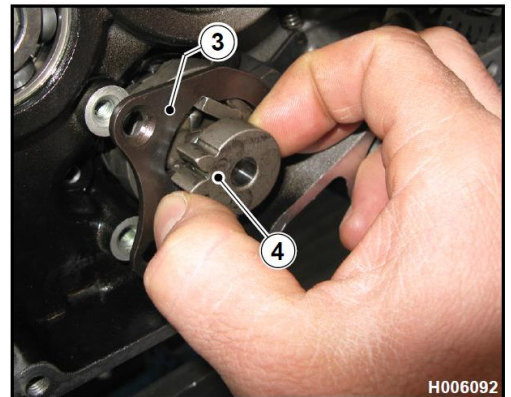



- Remove the drum (5) loosening the central shaft (6).

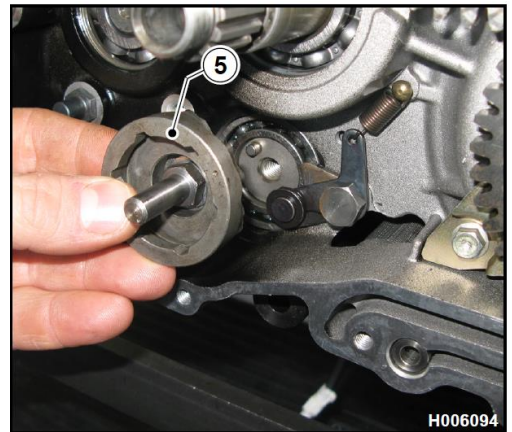
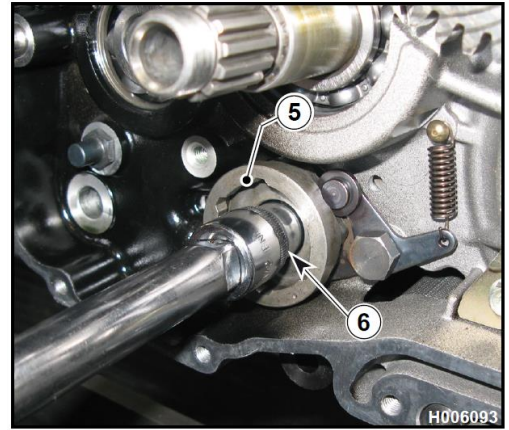

- Loosen the retaining screw (7) of the ratchet (8) and remove ratchet and spring (9).

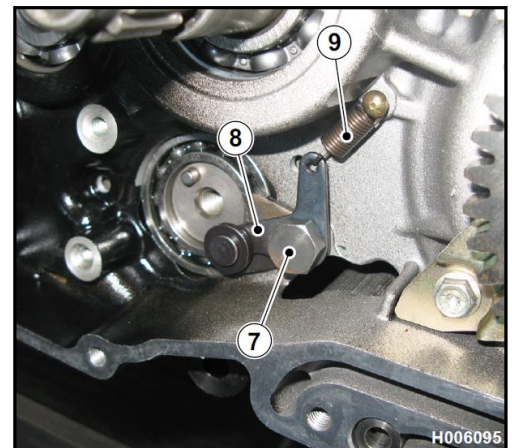

## Gear sensor removal

- Loosen the screws (1) using an 8 mm Allen wrench and remove the sensor (2).

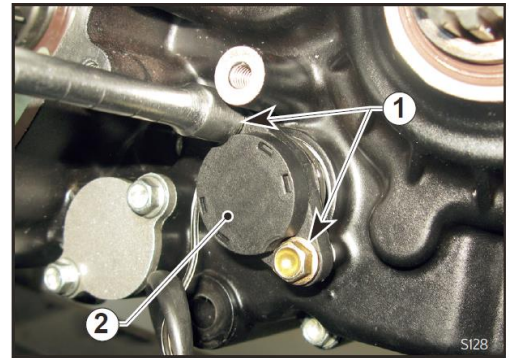

- Remove pushrod (3) and spring (4).

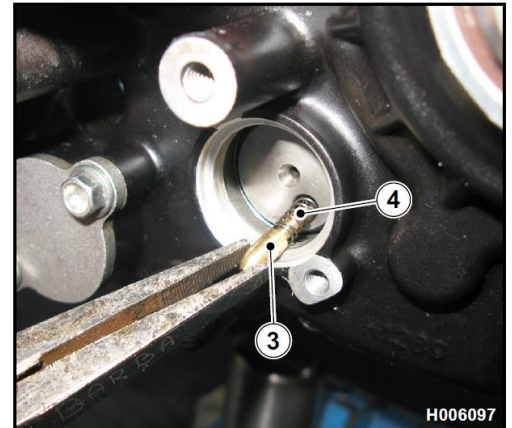

## Crankcase, crankshaft and countershaft disassembly

- Remove head, cylinder, piston, right and left crankcase, starter motor flange with starter motor, filters on flywheel side and gear sensor, as described in the relevant paragraphs.
- Remove bushing (1) on the sprocket shaft and extract the O-ring (2) using a small screwdriver.

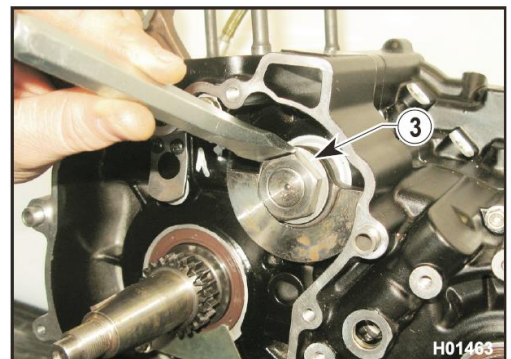
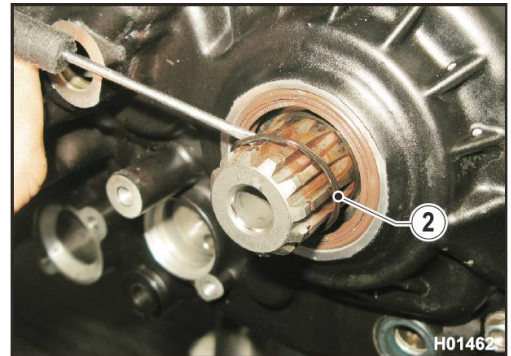
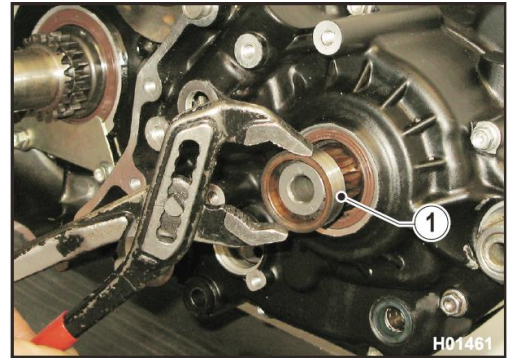

- Lift the tab of the lock washer (3).
- Place the engine in the dead centre.
- Loosen the countershaft nut (4) using an impact screwdriver and remove counterweight (5) and washer (3).

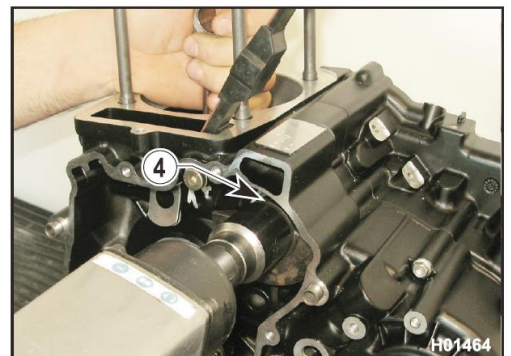

- Turn the engine over and lift the tab of lock washer (6).

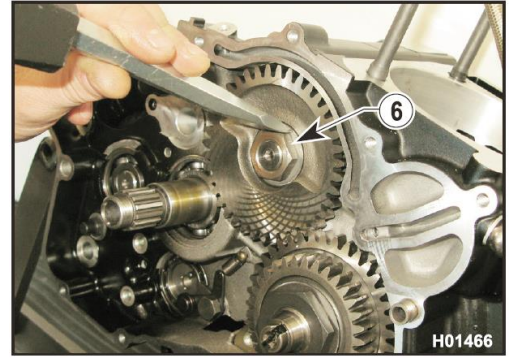

- Loosen the countershaft nut (7) using an impact screwdriver and remove gear (8) and washer (6).

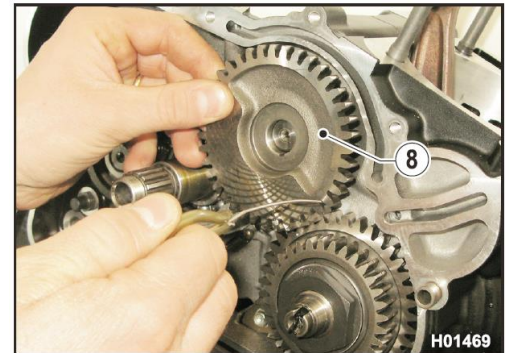
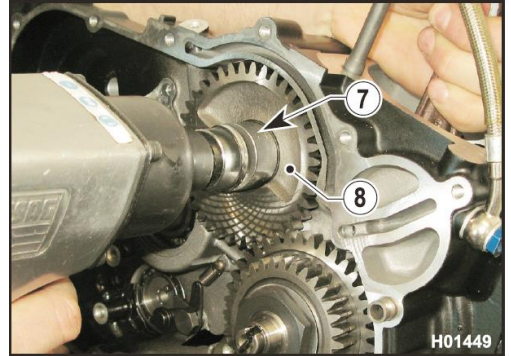

- Lift the tab of the lock washer (9).

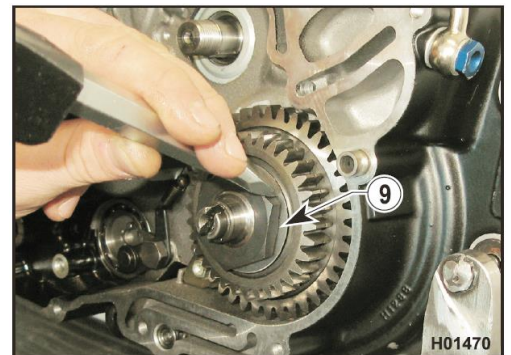

- Hold the connecting rod with one hand and loosen the crankshaft gear nut (10) using an impact screwdriver.

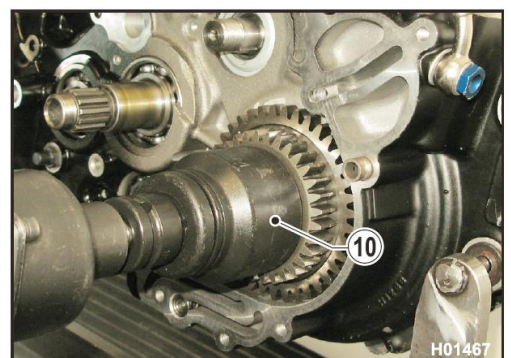

- Remove clutch housing drive gear (11) and countershaft drive gear (12).

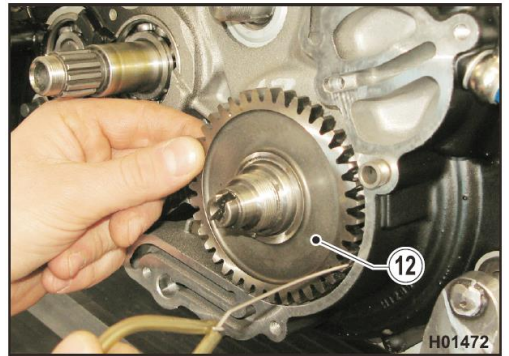
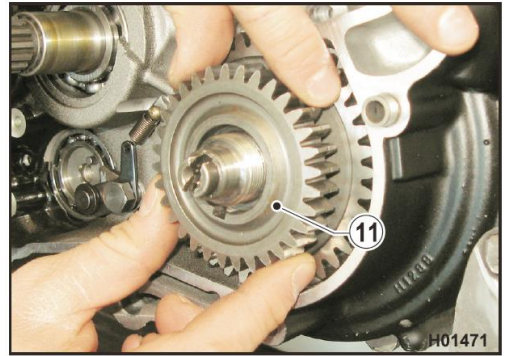

- Turn the engine over.
- Loosen the crankcase screws (12).

**WARNING**

The screws are not all the same length, mark them so as to refit them in their original positions on assembly; the central screws has a copper washer.

12a= M6x55 mm

12b= M6x55 mm + copper washer

12c= M6x55 mm

12d= M6x65 mm

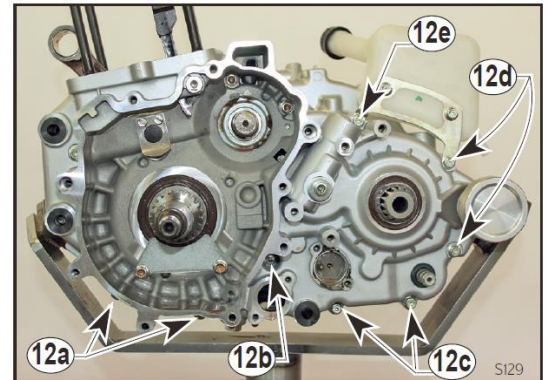

- Secure the puller to the left crankcase and separate the two crankcase halves.

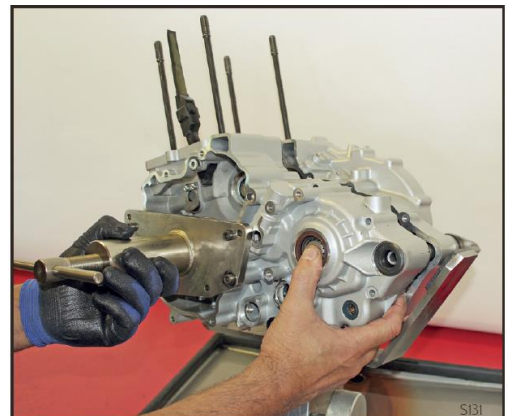
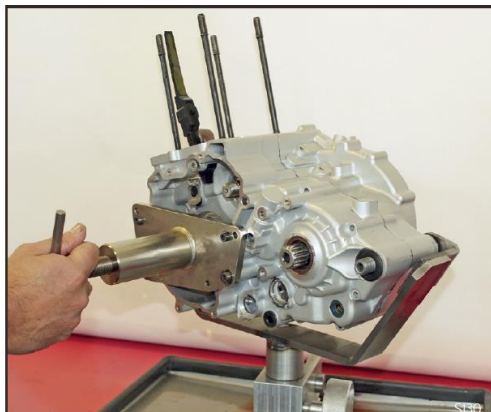

## Left crankcase seal replacement

- Remove the sprocket seal (1) with a screwdriver.
- Loosen the screws (2) and remove the plate (3) retaining the crankshaft seal (4).

**WARNING**

On assembly, position the seal flush with the crankcase.

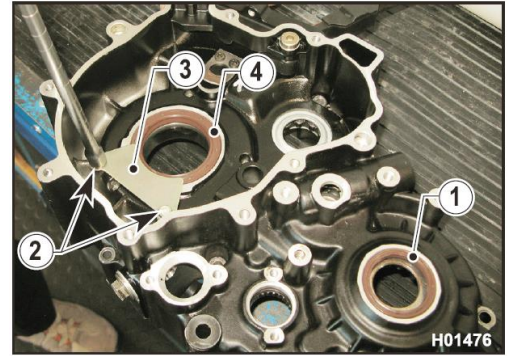

- Remove the seal (4) with a screwdriver.

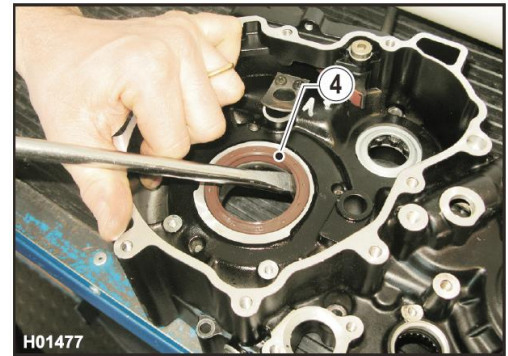

## Countershaft removal

- Tap the countershaft (1) with a rubber hammer and remove it from the crankcase.



## Gearbox disassembly

- Remove the shaft (1) of the output shaft shifter forks.

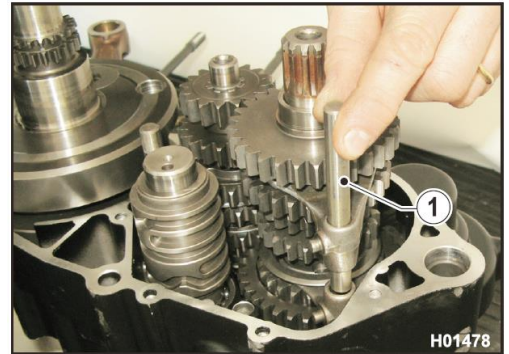

- Release the forks (2) and (3) from the drum (4) and remove them.

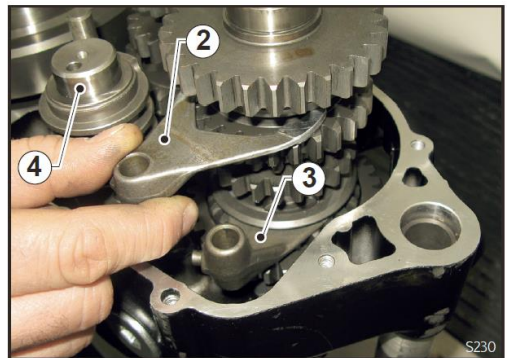

- Remove the input shaft fork shaft (5) and remove the drum (4).



- Remove the input shaft fork (6).

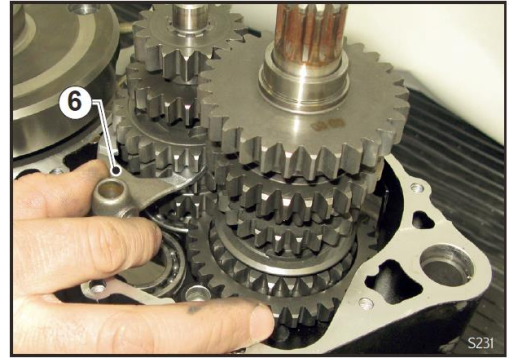

- Remove input shaft (7) and output shaft (8) being careful not to lose any shims (if fitted).

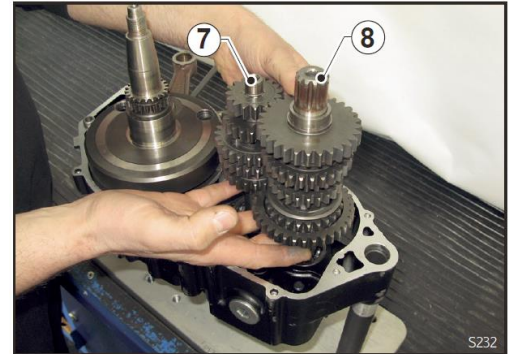

## Crankshaft removal

- Slide the puller (1) over the right end of the crankshaft.

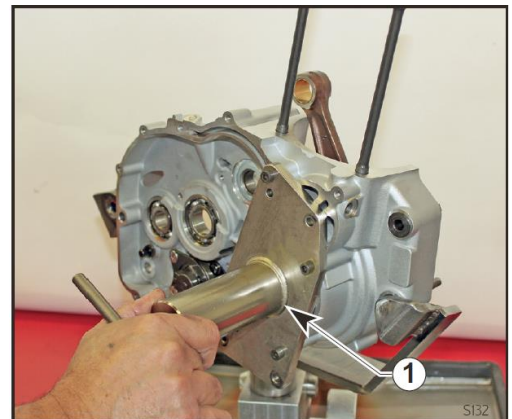

- Secure the puller to the crankcase half and remove the crankshaft (2) from the opposite side.

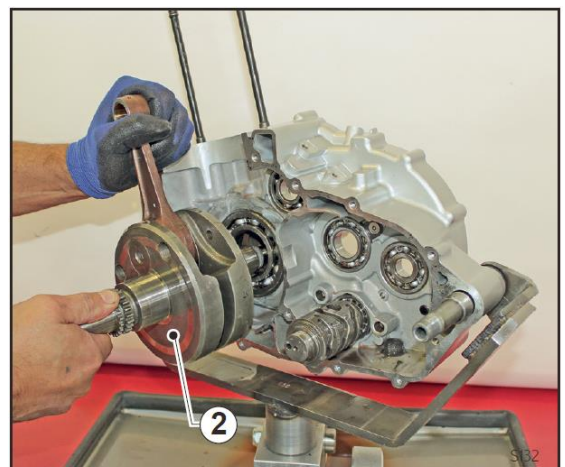



## Crankshaft components removal

- Insert a plate (1) between the two flywheel halves.
- Remove the crank pin from one of the flywheel halves using a press. Remove connecting rod and needle roller bearing.
- Turn the shaft and remove the crank pin (2).
- Remove the threaded cap and clean the crank pin.

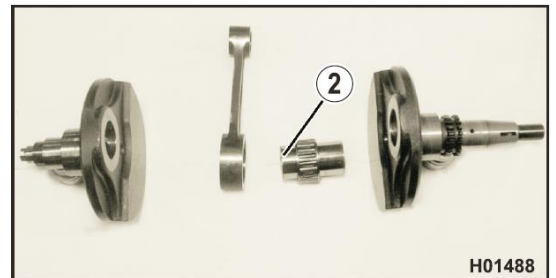
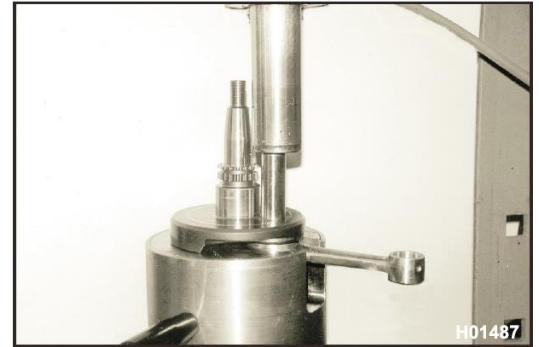
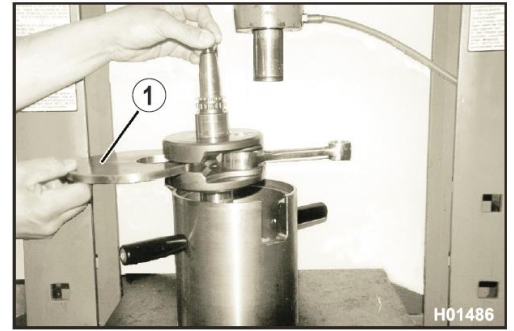

## Right crankcase crankshaft seal removal

- Loosen the screw (1) and remove the plate (2).
- Remove the seal (3) with a screwdriver.

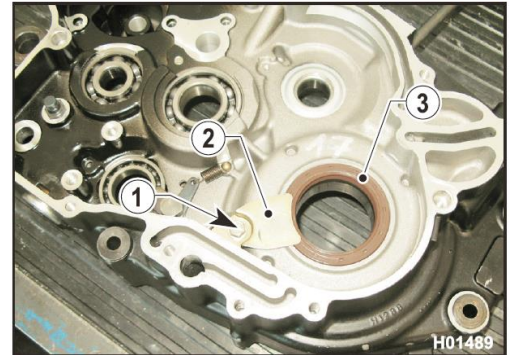

## Crankcase bearings removal

- Remove the retaining plates (1) and (2) from the crankcase halves.

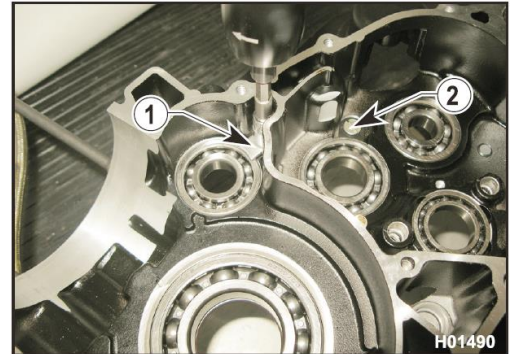

- Heat up the crankcase halves to around 125 °C in a furnace and extract the bearings using a suitable driver tool.

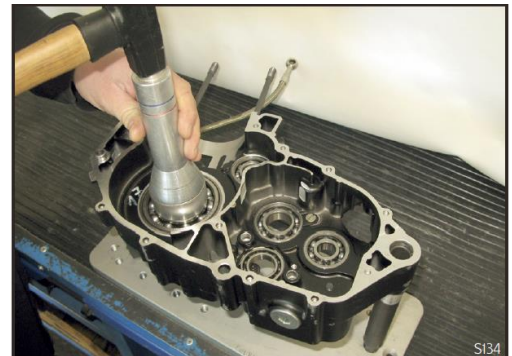

## Oil pump disassembly

- Take the clutch cover (which you have removed previously) and remove the four screws (1) securing the small cover; remove all components until getting to the oil pump drive shaft (2).

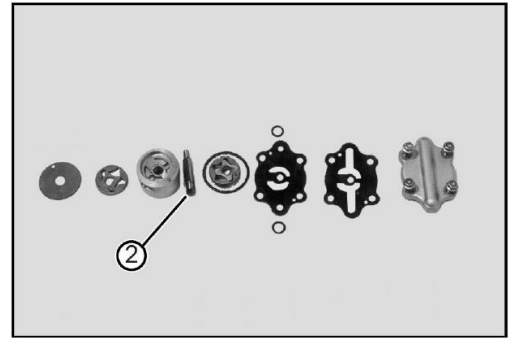

## Stator removal

- Take the ignition cover (which you have removed previously) and remove the screws (1) and (2);
- Remove stator (3) and pick-up sensor (4) from the left cover.

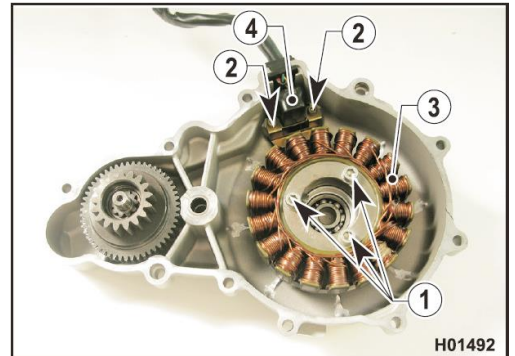

# Chapter C.

---

## Engine Components and Details

## INFORMATION AND SAFETY TIPS

### Cleaning parts

All parts must be cleaned with gasoline and dried with compressed air.

### Clearances

To ensure the best operating conditions and maximum performance, all clearances must be within the specified tolerance. A tight fit will lead to seizure as moving parts heat up, whereas a loose fit will cause annoying vibration resulting in early wear of moving parts.

**DANGER**

Flammable vapors develop during this procedure and metal filings blown by compressed air may get into your eyes. Perform this procedure away from open flames or sources of ignition and wear an eye protection.

## ENGINE COMPONENTS AND DETAILS

### Cylinder head

- Remove fouling deposits from the combustion chamber using a rounded scraper.
- Check the machined surface of the cylinder head for warpage using a straight-edge and a feeler gauge at the positions shown in the figure. If warpage exceeds the service limit at any one point, grind the cylinder mating surface.
- Head warpage: service limit 0.05 mm (0.002 in.).

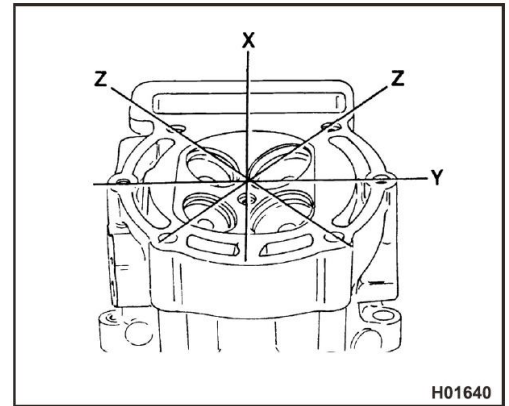

### Valve seat refacing

- Clean off any fouling deposits from the valve. Apply Prussian Blue to the valve and rotate it in its seat using a rubber hose or other similar tool.
- Remove the valve and measure the width "X" of the seating face. If width is greater than 1.5 mm (0.059 in.), the seat needs to be refaced.
- The standard width (measured as shown) of the seating face of the valve is, see Table 1 - Standard measurements for Valve seat refacing.

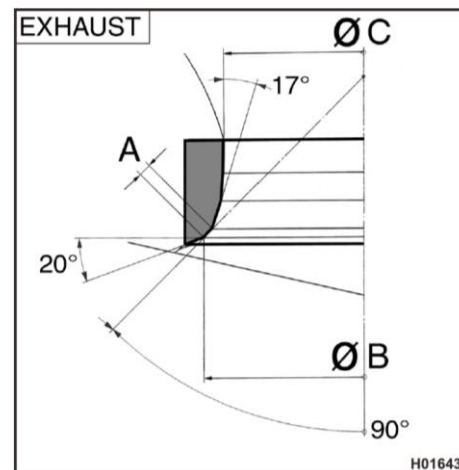
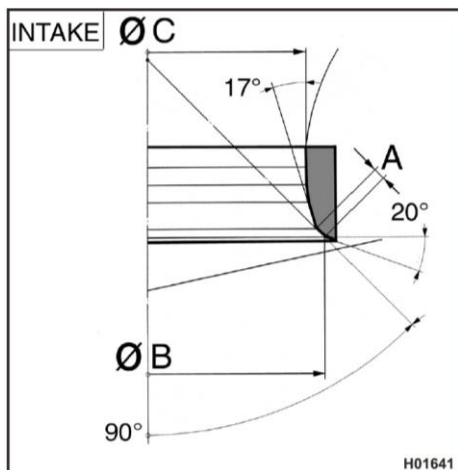
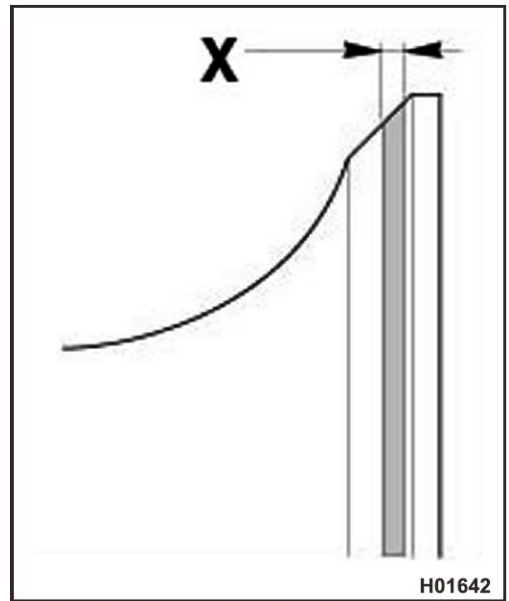

	Intake	Exhaust
A	0.9 - 1.1 mm (0.035 - 0.043 in.)	0.9 - 1.0 mm (0.035 - 0.039 in.)
B	36.60 - 36.65 mm (1.441 - 1.443 in.)	30.60 - 30.65 (1.205 - 1.207 in.)
C	33 mm (1.229 in.)	27.5 mm (1.083 in.)

Table 1 - Standard measurements for Valve seat refacing.

- Inspect valve seat and reface it if you find any signs of damages. Correct valve seating position is very important. Use a dye to check seat contact surface position, it should be 0.5 mm (0.02 in.) from valve edge.

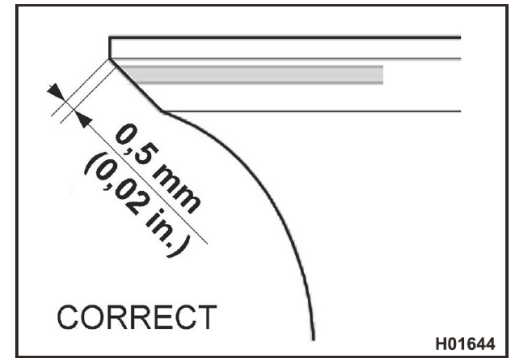

- If seat contact surface is too low on valve face, reface the seat with 73° and 45° cutters.

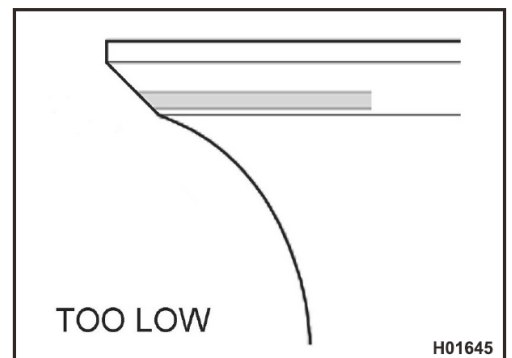

- If the contact surface is too high on valve face, reface the seat with 20° and 45° cutters.
- Ensure that seat contact surface is the correct width.

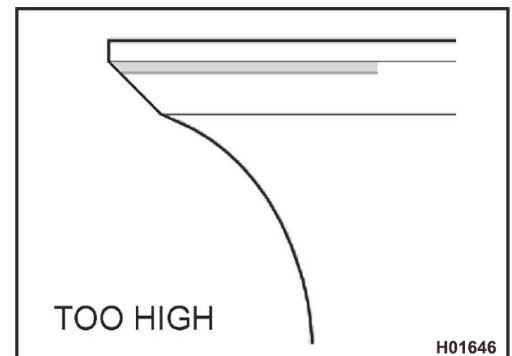

## Valve guide

- Perform a careful visual inspection of the valve guide.
- To determine wear, measure valve to valve guide clearance in the “x” and “y” directions (at right angles to each other) using a suitably positioned dial gauge.
- Intake valve: normal clearance: 0.008 - 0.035 mm (0.0003-0.0014 in.)
- Service limit: 0.05 mm (0.002 in.)
- Exhaust valve: normal clearance: 0.018 - 0.045 mm (0.0007 - 0.0018 in.)
- Service limit: 0.08 mm (0.0031 in.)

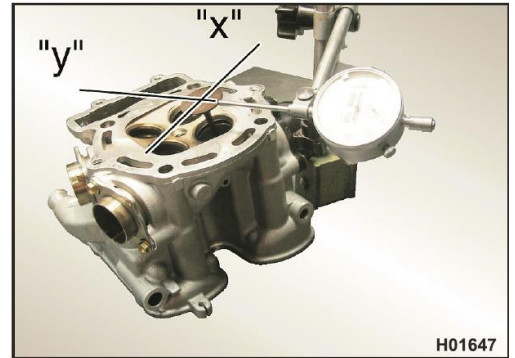

## Valve guide replacement

- Remove the valve guide from the cylinder head using a suitable punch.
- Make sure that the cylinder head is not damaged.

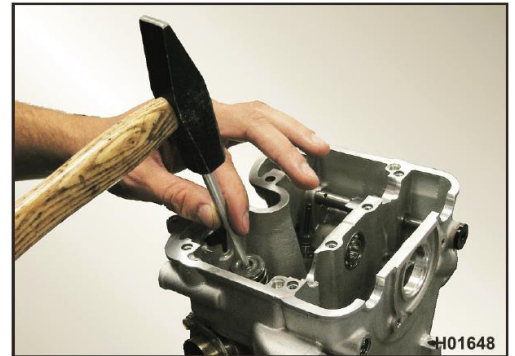

- Heat up the head in a furnace up to 170 °C.
- Install the new guide from the top of the head using a suitable punch. Smear the guide with oil before installation. Fit new sealing rings.

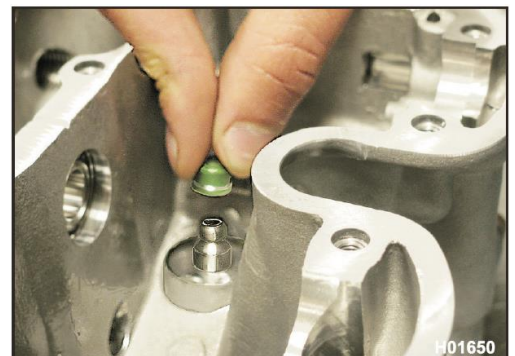
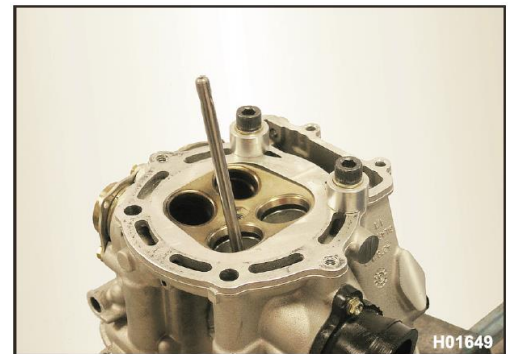



- Ream the valve guide using a suitable reamer and lubricate with cutting fluid. Rotate the reamer when extracting it to avoid scoring the valve guide.

**WARNING**

When a valve guide is changed, the valve seat must be refaced.

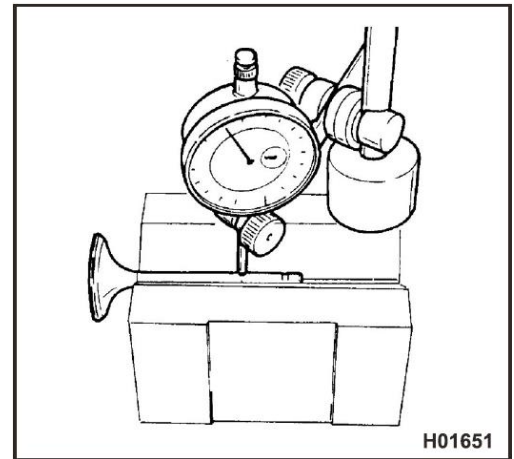

## Valve guide replacement

- Inspect valve stem and valve seating face to make sure they are in good condition. There should be no signs of pitting, cracking, distortion or wear. Check for the following:
  - Valve stem run-out: place valve on a V block and measure run-out with a dial gauge. (Service limit: 0.05 mm (0.002 in.)).
  - Valve head out-of-round: place valve on a V block and check with a dial gauge at right angles to the head while turning the valve. (Service limit: 0.03 mm (0.0012 in.)).

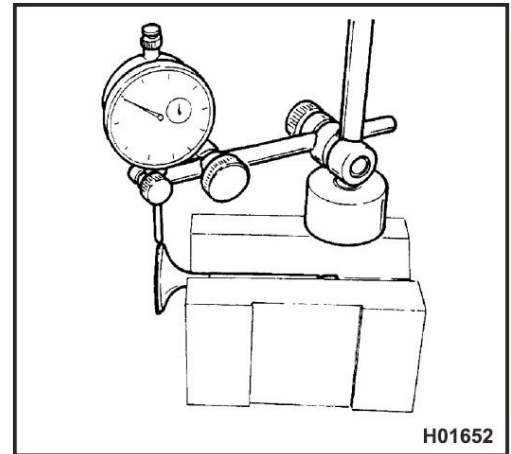

## Valve Spring

- Check free length "L". If outside the specified service limit, replace the springs.
- Spring: L = 43.4 mm (1.709 in.) - Service limit: 41 mm (1.614 in.)

**WARNING**

Replace all valve springs whenever anyone spring exceeds the service limit.

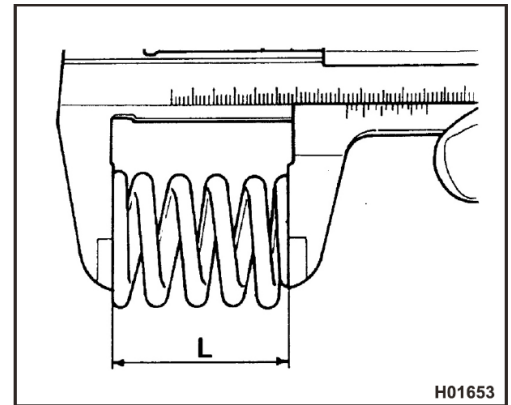

- Check the valve springs for proper squareness.
- Maximum acceptable deviation is 1.5 mm (0.059 in.) on each side.

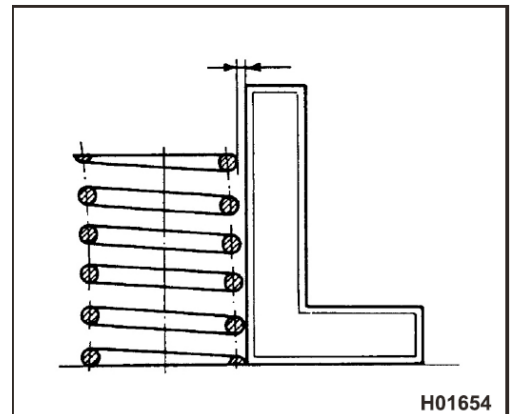

## Valve installation

- Smear valve guides and stems with oil before installation.
- Fit sealing ring (1), springs (2) and valve spring retainer (3).
- Compress the valve springs and install the valve collets (4).
- The section of the spring must face the cylinder head.

WARNING

Do not compress the springs too much on installation and avoid damage to the cylinder head.

- Lightly tap valve stem with a plastic hammer to help the valve collets become fully seated.

WARNING

Tap the valve stem tip to avoid pushing the valve off center.

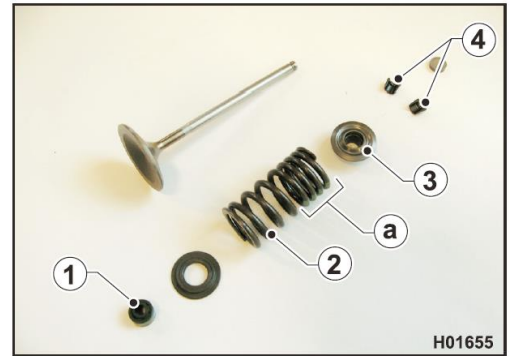

## Rocker arm Inspection

- Check rocker arm to shaft clearance. Measure rocker arm inside diameter and shaft diameter and calculate clearance. Maximum clearance 0.1 mm (0.004 in.). If the limit is exceeded, replace both rocker arms. On assembly, tighten shaft bolts to 25 Nm (2.55 Kgm or 18.4 ft/lb).
- (+LOCTITE 243).

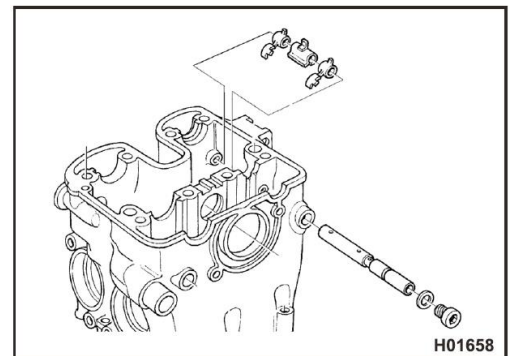

## Camshaft

- Check the contact faces of the lobes for streaks, scoring, dents and waviness. Clamp the camshaft between centres and check deviation using two dial gauges. Service limit: 0.1 mm (0.004 in.). Check that the lobes are in pristine conditions, without signs of scoring or distortion.
- Height "H" of lobes when new:
  - Intake = 36.57 mm (1.44 in.)
  - Exhaust = 35.94 mm (1.415 in.)

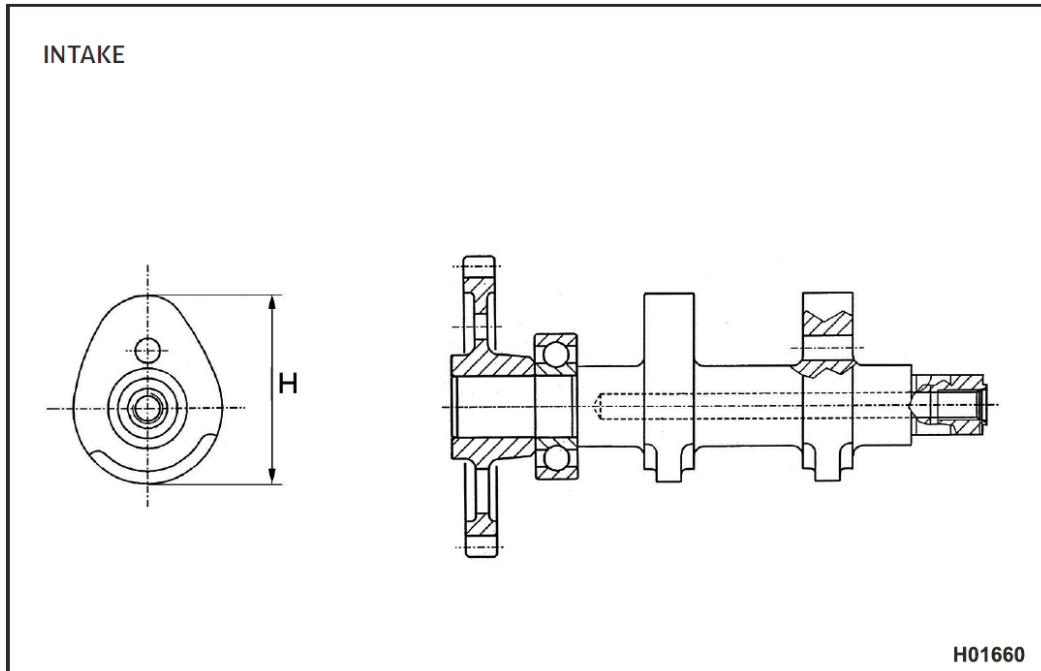
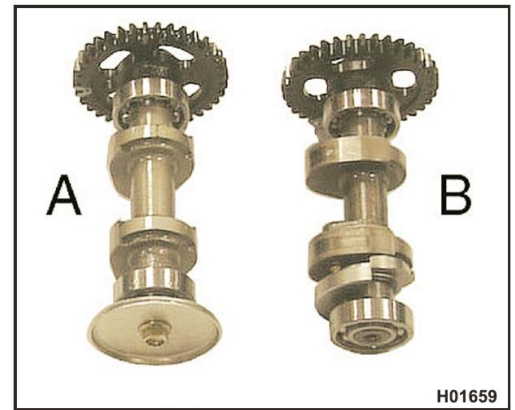

EXHAUST

B)

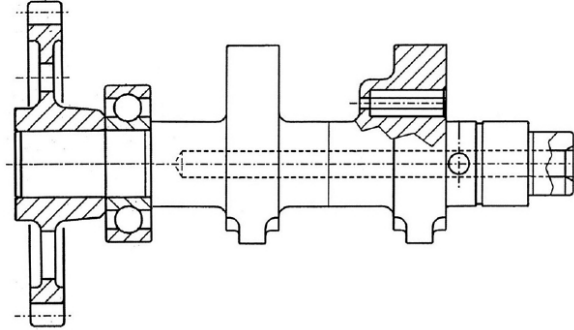
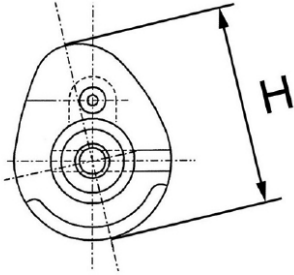

H01661

## Timing chain and gears

- Check the chain for wear at each engine overhaul.
- Replace chain if too noisy or worn.

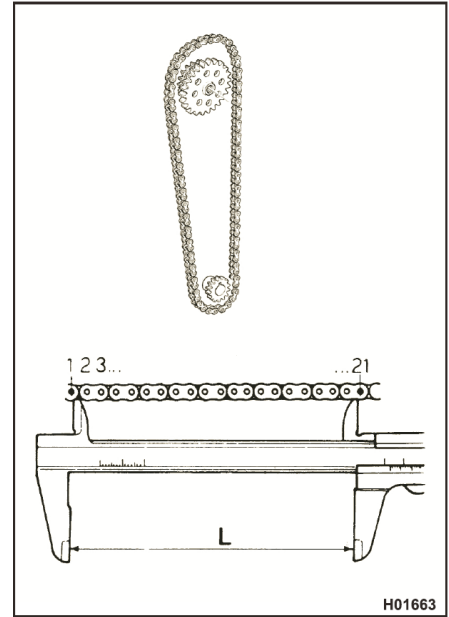

## Timing chain tensioners

- Chain tensioners must be replaced when the lower area of the wear indicators is worn down to the metal.

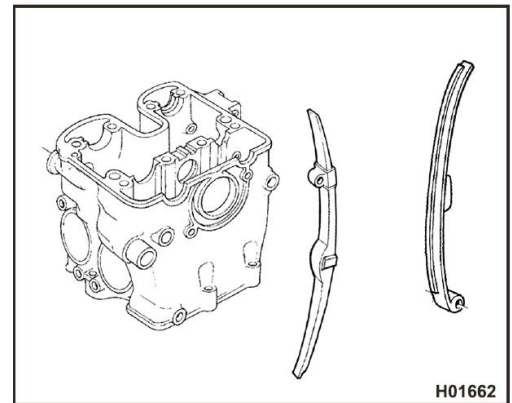

## Cylinder

- Check the walls for dents or scuffing. Measure cylinder bore diameter at three different positions. Measure each diameter in two directions at right angles to each other to determine taper and out-of-round.
- Max. taper (wear limit): 0.05 mm (0.002 in.).
- Max. out-of-round (wear limit): 0.05 mm. (0.002 in.)
- If cylinder is worn beyond these limits, replace both cylinder and piston. The liner undergoes a special hardening treatment and cannot be ground.

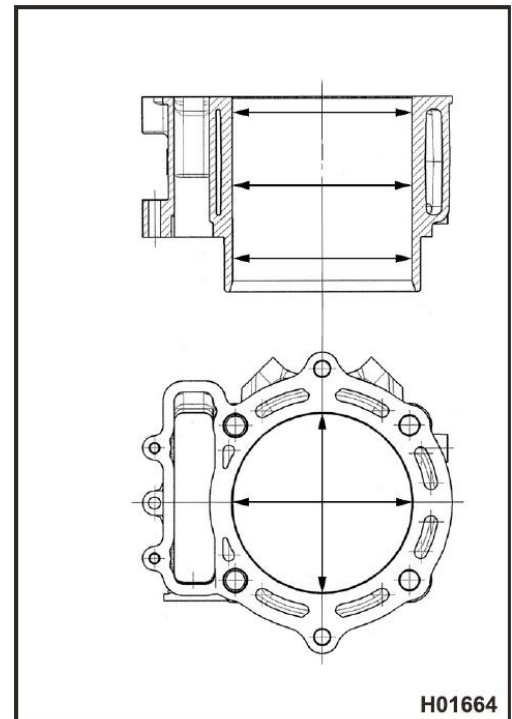

## Piston

- Clean off any carbon deposits from piston crown and grooves. Perform a careful visual inspection of the piston and check its dimensions. There should be no signs of forcing, scuffing, cracking or other damage.

## Cylinder to piston clearance

- Cylinder diameter
  - Measure inside diameter (Dc) with an internal bore micrometre 10 mm (0.394 in.) below the edge (distance “A”).
- Piston diameter
  - Measure piston diameter (Dp) 8-9 mm (0.315-0.354 in.) above skirt edge (distance “B”).
- Clearance is calculated as follows = Dc-Dp.

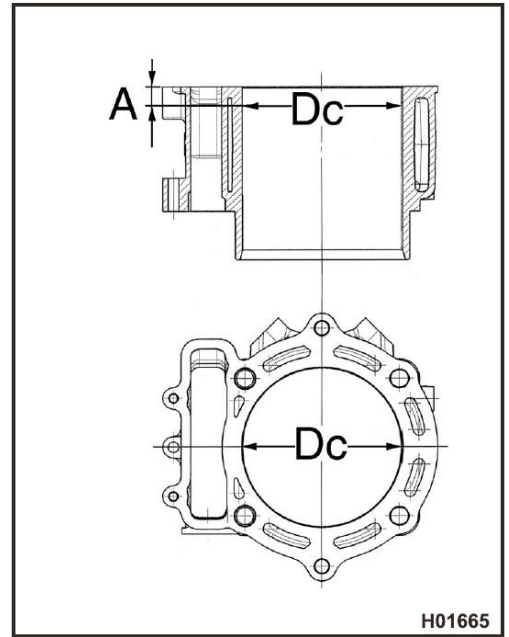

**Clearance (Dc-Dp)**

0.025-0.055 mm  
(0.0010-0.0022 in.)

**Service Limit**

0.12 mm  
(0.0047 in)

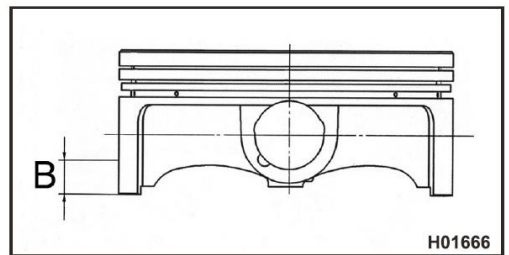

## Piston pin

- The piston pin must be perfectly smooth, with no signs of scoring, dents or bluing due to overheating.

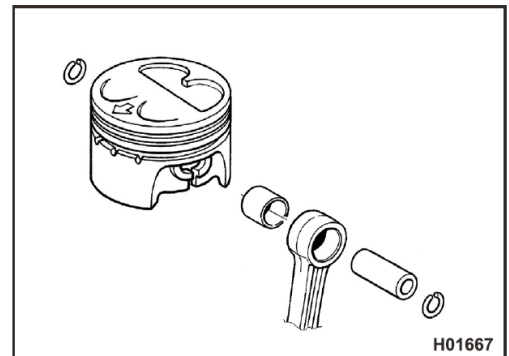

## Piston rings

- They should show no signs of forcing or scoring.
- Replacement pistons come with piston rings and piston pin.

## Piston ring to cylinder clearance

- Insert the piston ring at the bottom of the bore (where minimum wear occurs) taking care to position it squarely and measure end gap.

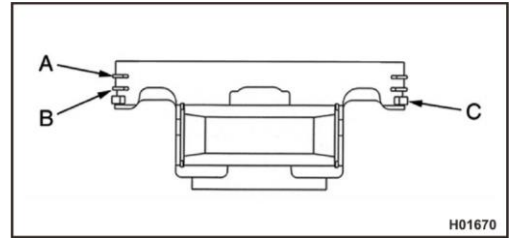

Piston Ring	Mounting Clearance (H)	Service Limit
A	0.20-0.45 mm (0.00787-0.0177 in.)	0.7 mm (0.027 in.)
B	0.20-0.45 mm (0.00787-0.0177 in.)	0.7 mm (0.027 in.)
C	0.10-0.20 mm (0.00394-0.00787 in.)	0.35 mm (0.014 in.)

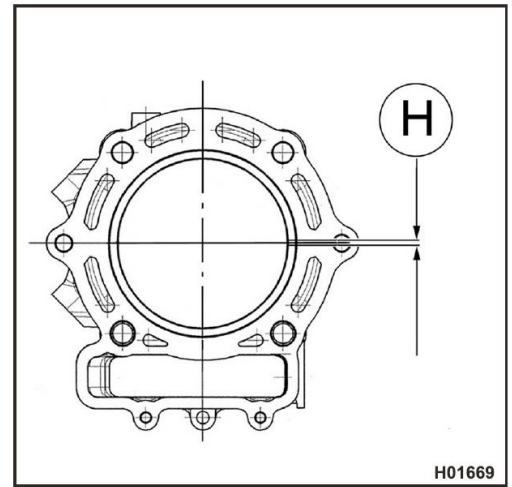



## Piston ring to groove clearance

- Use a feeler gauge to measure the axial clearance (H) of piston rings. If the piston ring is marked on one side, that side must be facing up.
- \* - position of end gap "d"

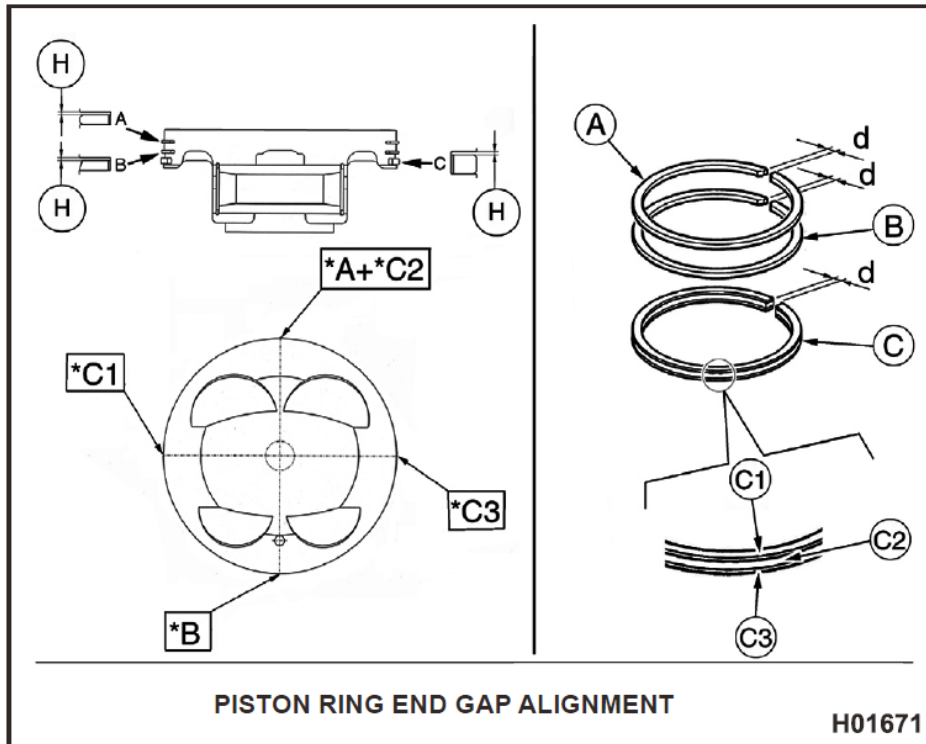

Piston Ring	Mounting Clearance (H)	Service Limit
A	0.030-0.065 mm (0.00012-0.0025 in.)	0.13 mm (0.0051 in.)
B	0.020-0.055 mm (0.0008-0.0022 in.)	0.11 mm (0.0043 in.)
C	0.010-0.180 mm (0.0004-0.0071 in.)	0.35 mm (0.0138 in.)

## Small end and big end rod clearance

- Piston pin to small end clearance (A)
- Big end side clearance (B)

	Mounting Clearance (H)	Service Limit
A	0.012-0.027 mm (0.0005-0.0011 in.)	0.055 mm (0.0022 in.)
B	0.026-0.036 mm (0.001-0.0014 in.)	0.080 mm (0.0031 in.)

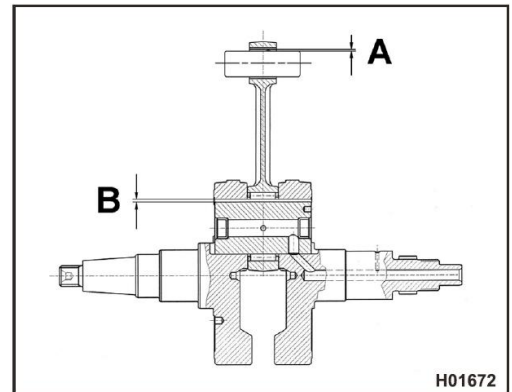

## Big end radial clearance

Standard	Wear Limit
0.02-0.028 mm (0.0008-0.00112 in.)	0.04 mm (0.0016 in)

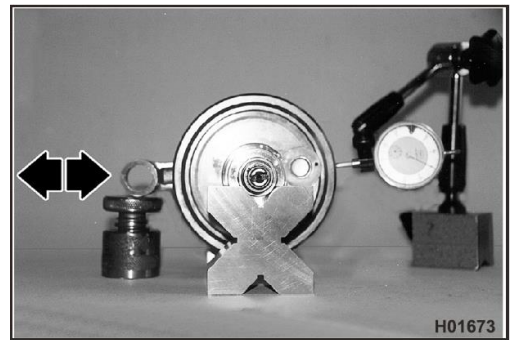

Standard	Wear Limit
0.50-0.70 mm (0.0197-0.0275 in.)	0.080 mm (0.00315 in)

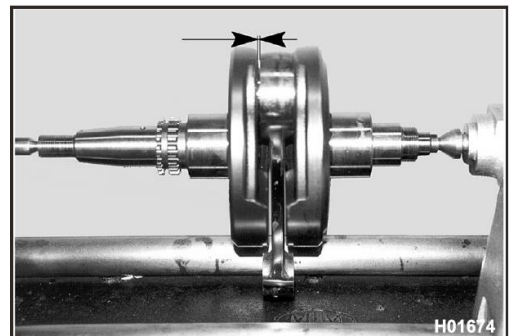

## Big end radial clearance

- Clamp the countershaft between centres and check that journals run concentric using a dial gauge (maximum run-out allowed 0.02 mm (0.0008 in.)).
- Measure diameters A,B,C and D:
  - $\varnothing A$  wear limit = 16.945 mm (0.6671 in.).
  - $\varnothing B$  wear limit = 19.965 mm (0.786. in.).
  - $\varnothing C$  wear limit = 19.965 mm (0.786. in.).
  - $\varnothing D$  wear limit = 19.960 mm (0.7858 in.).

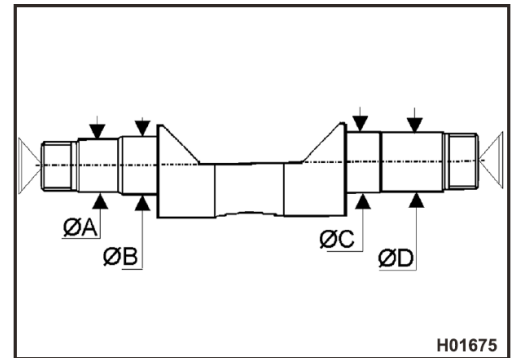

## Crankshaft

- Main journals and crank pins should show no scoring or scuffing. Threads, keyways and splines must be in good condition.
- Clamp the shaft between centres and check that crank pins run concentric using a dial gauge (maximum runout allowed 0.02 mm (0.0008 in.)).

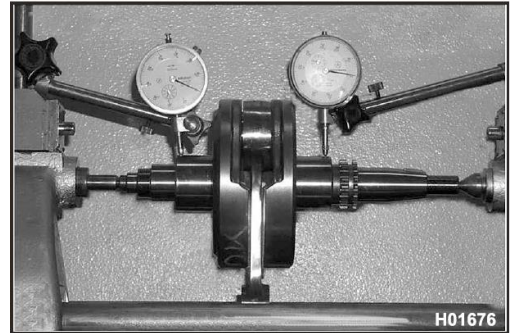

## Crankshaft straightness

Standard	Wear Limit
less than 0.03 mm (0.012 in)	0.05 mm (0.0019 in)

## Small end bushing replacement

- You will need an appropriate punch and a press to change the bushing. Smear the outer face of the bushings with moly grease before installation.
- The bushing should be mounted with an interference fit of: 0.049-0.095 mm (0.00196-0.0038 in.) Match the oil holes of the new bushing with those in the connecting rod; ream the bushing bore to 20 mm  $\frac{+0.022}{+0.012}$  (0,79 in.  $\frac{+0,00088}{+0,00048}$ ).
- Check bore concentricity as shown in the diagram.

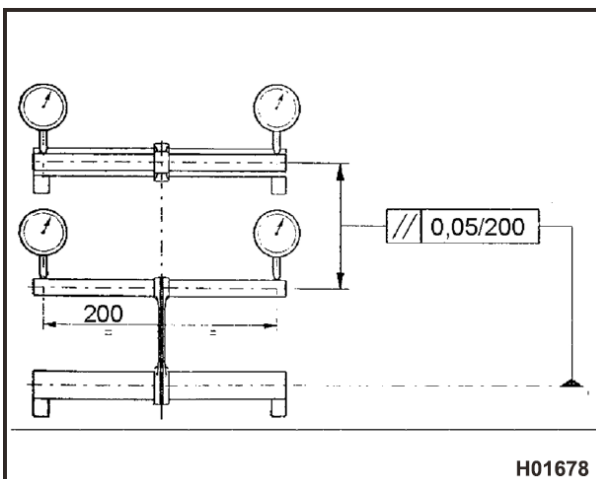
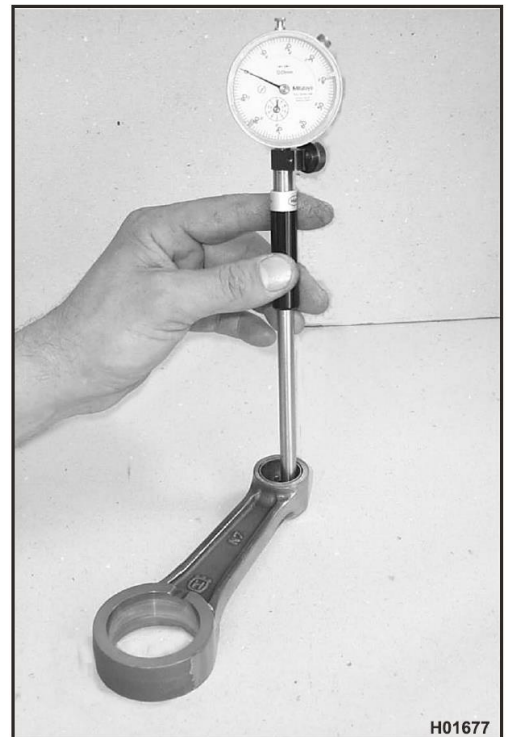

## Clutch

- Inspect all clutch components to make sure they are in the best conditions. Clutch plates should show no signs of bluing, scoring or distortion. Measure the thickness of friction plates.
- Plate thickness when new: 2.92-3.08 mm (0.1149-0.1212 in.)
- Service limit: 2.65 mm (0.106 in.).
- Place each (friction and steel) plate on a surface plate and check for distortion using a feeler gauge; Use a feeler gauge.
- Service limit: 0.15 mm (0.006 in.)

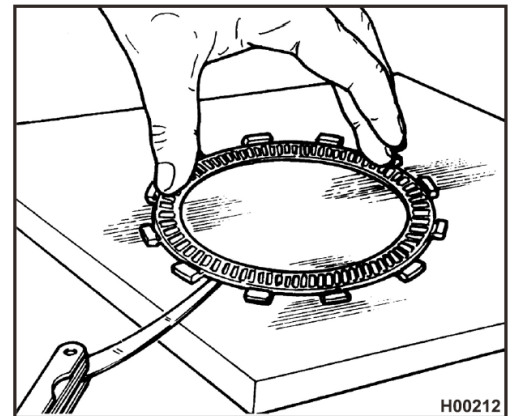
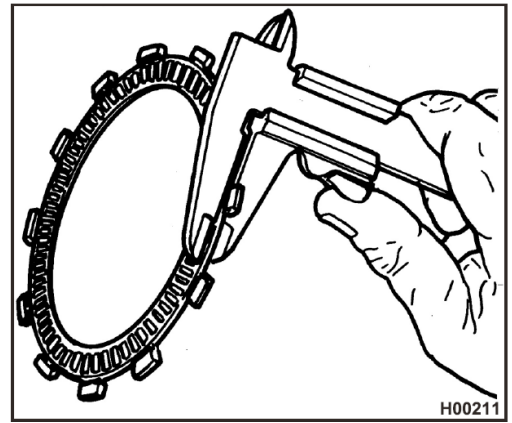

## Friction plate to clutch housing clearance

- Measure clearance "A" between clutch housing (2) and plate (1) with a feeler gauge and compare measured clearance with the table below.

Standard	Service Limit
0.30-0.50 mm (0.012-0.020 in.)	0.6 mm (0.024 in.)

**WARNING**

If measured clearance exceeds the service limit, replace clutch plates or housing and repeat measurement. If measurement is still outside the service limit, replace the complete clutch assembly.

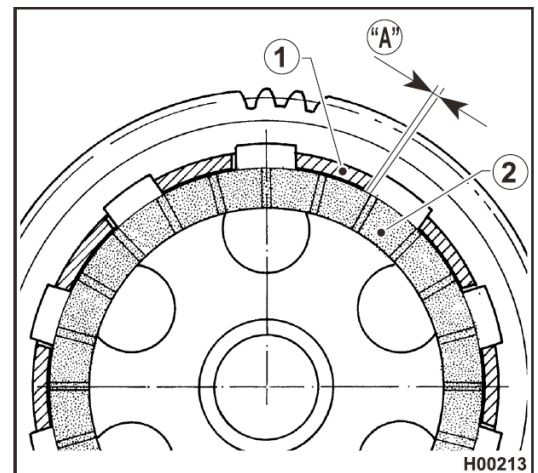

## Clutch spring

- Measure the free length "L" of each spring with a calliper.
- New spring L= 41 mm (1.61 in.).
- Service limit: 39 mm (1.38 in.).
- Change any spring that is outside the service limit.

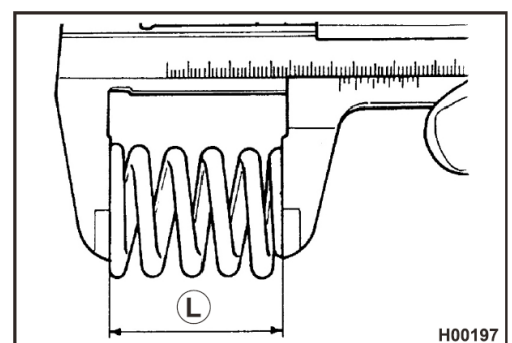

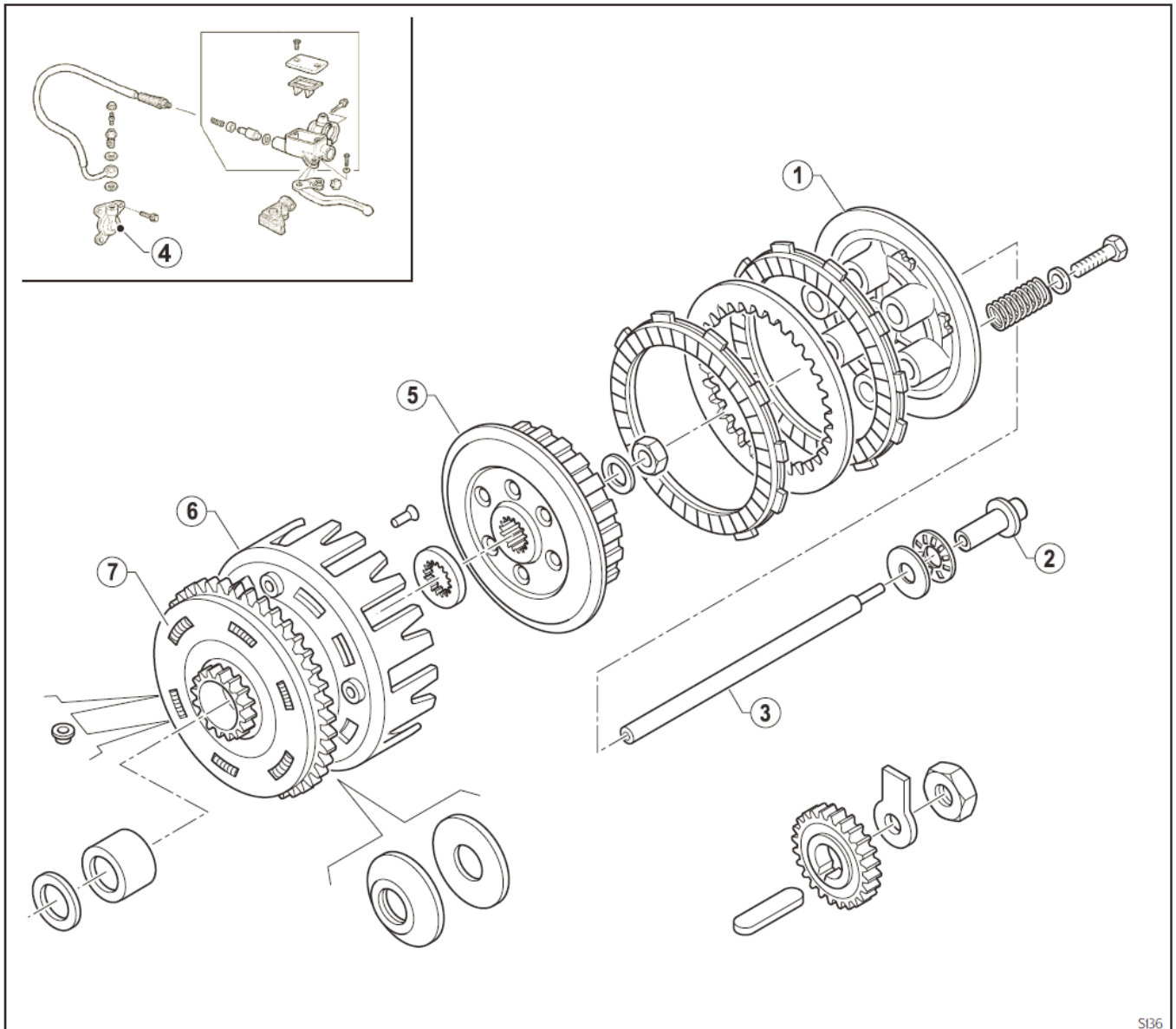

SI36

- 1- Pressure plate;
- 2- Clutch actuator plate;
- 3- Pushrod;
- 4- Piston assembly: Check these parts for signs of wear or failure. If any are found, replace the part;
- 5- Clutch hub: Check the steel plate slots for signs of wear or failure. If any are found, replace the part;
- 6- Clutch housing: Check the friction plate slots for signs of wear or failure; Check the needle roller bearing seats for signs of wear. If any are found, replace the part;
- 7- Primary drive gear pair: Check gear teeth for signs of wear or failure. If any are found, replace the part.

## Shifter forks and gears

- Visually inspect the shifter forks (1) and replace any bent forks. A bent fork will make gears hard to engage or let the transmission jump out of gear unexpectedly under loading.
- Check the clearance of the each shifter fork in its gear groove using a feeler gauge. If any one of the three gears is outside the service limit, measure the width of gear groove and fork thickness to determine which component needs to be replaced. Shifter fork to groove clearance (new fork and gear): 0.070 - 0.225 mm (0.0028 - 0.0088 in.)
- Service limit: 0.26 mm (0.010 in.).

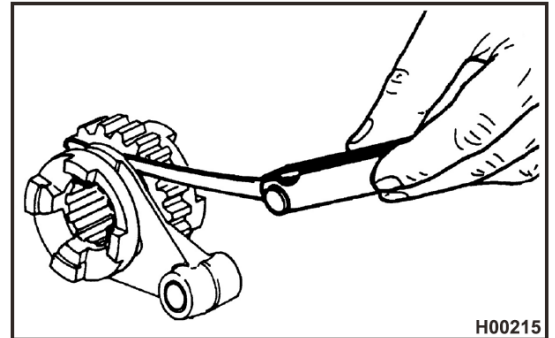
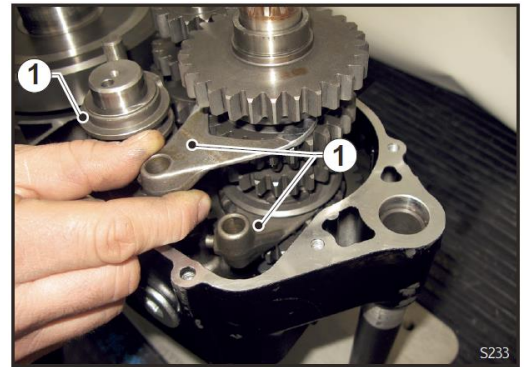

## Selector drum

- Check drum grooves for wear or dents and make sure the selector drum is not bent, worn or damaged.

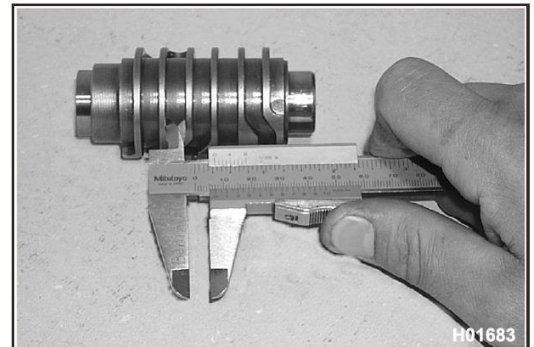

## Selector drum to shifter fork pins clearance

- Determine clearance between shifter fork pin and drum groove taking the necessary measurements with a calliper. If service limit is exceeded, compare the components with new parts to determine which one needs to be removed.
- Shifter fork to drum groove clearance (from new): 0.15-0.35 mm (0.006-0.014 in.)
- Service limit: 0.5 mm (0.02 in.)

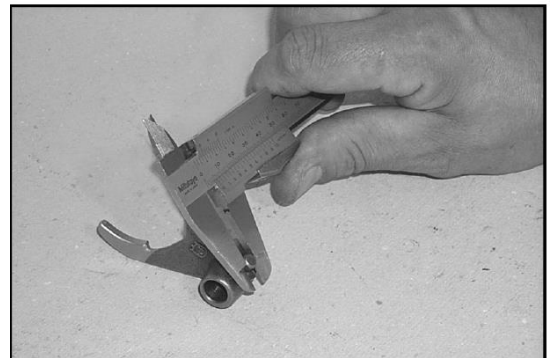

## Oil pump disassembly

- Remove the oil pump from the right crankcase as described in the Section "F".
- Check side clearance to determine whether the pump needs replacing; use a feeler gauge and a straight-edge.
- If pump rotors (1) and (2) have been separated from pump body, make sure to line up the dots on inner and outer rotors on assembly. Check pump body mating face for scoring, dents or scuffing.
- Side Clearance: 0.10 mm (0.0039 in.)

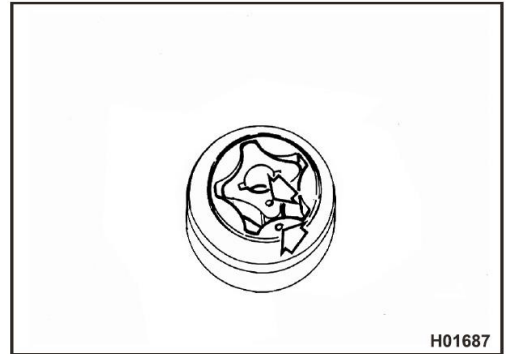
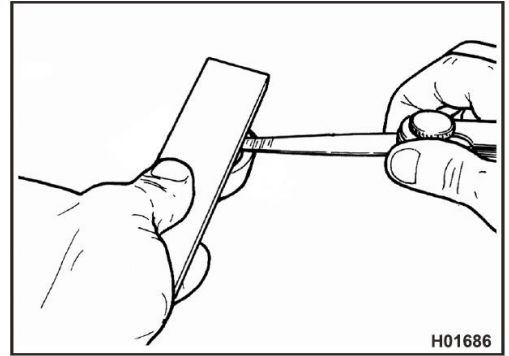

**WARNING**

On assembly, inspect the seals (3) and make sure the pins (4) are located correctly; for tightening torque figures, see Sections "H" and "X".

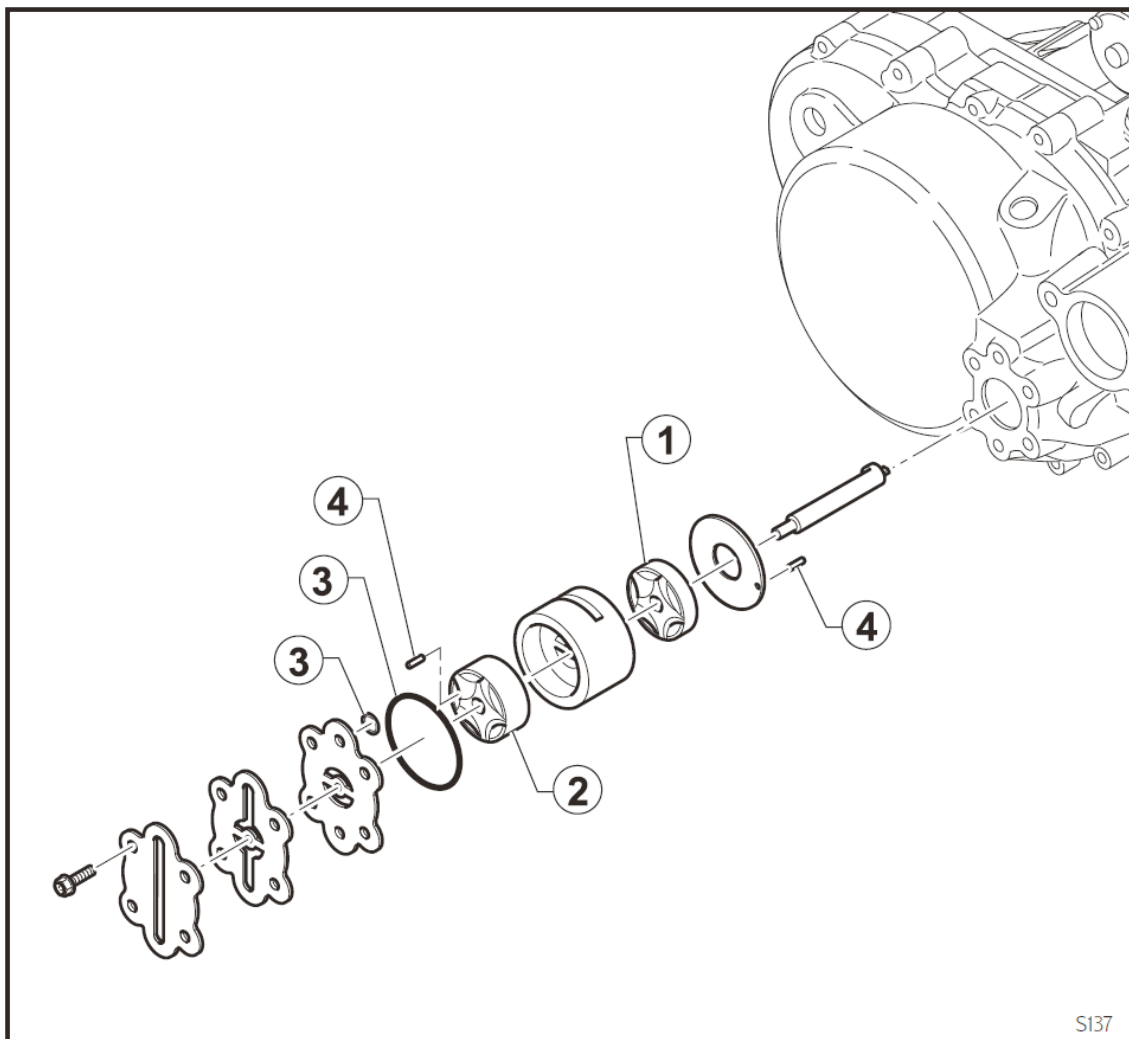



# Chapter D.

---

## Engine Reassembly

## GENERAL INFORMATION

- To reassemble, reverse the disassembly procedure.
- Any special instructions concerning reassembly are expressly highlighted in the text.
- Always replace gaskets, oil seals, metal retainers, sealing washers made from deformable material (copper, aluminium, fibre, etc.) and self-locking nuts after removal.
- Bearing specifications and dimensions have been calculated for a certain life. We recommend replacing the bearings - especially those exposed to heavy loading - also considering that checking them for wear is not an easy procedure.
- These recommendations are in addition to the dimensional checks of individual components specified in the relevant section (see Chapter\_A\_Engine).
- Cleaning all components thoroughly is critical to reliability; bearings and any wear parts must be lubricated with engine oil before assembly.
- Screws, nuts and bolts must be tightened to the specified torque (see Tightening\_Torque\_Figures)

## Assembly and Lubrication Instructions

- Crank - Alternator - Lubrication - Left Crankcase Half

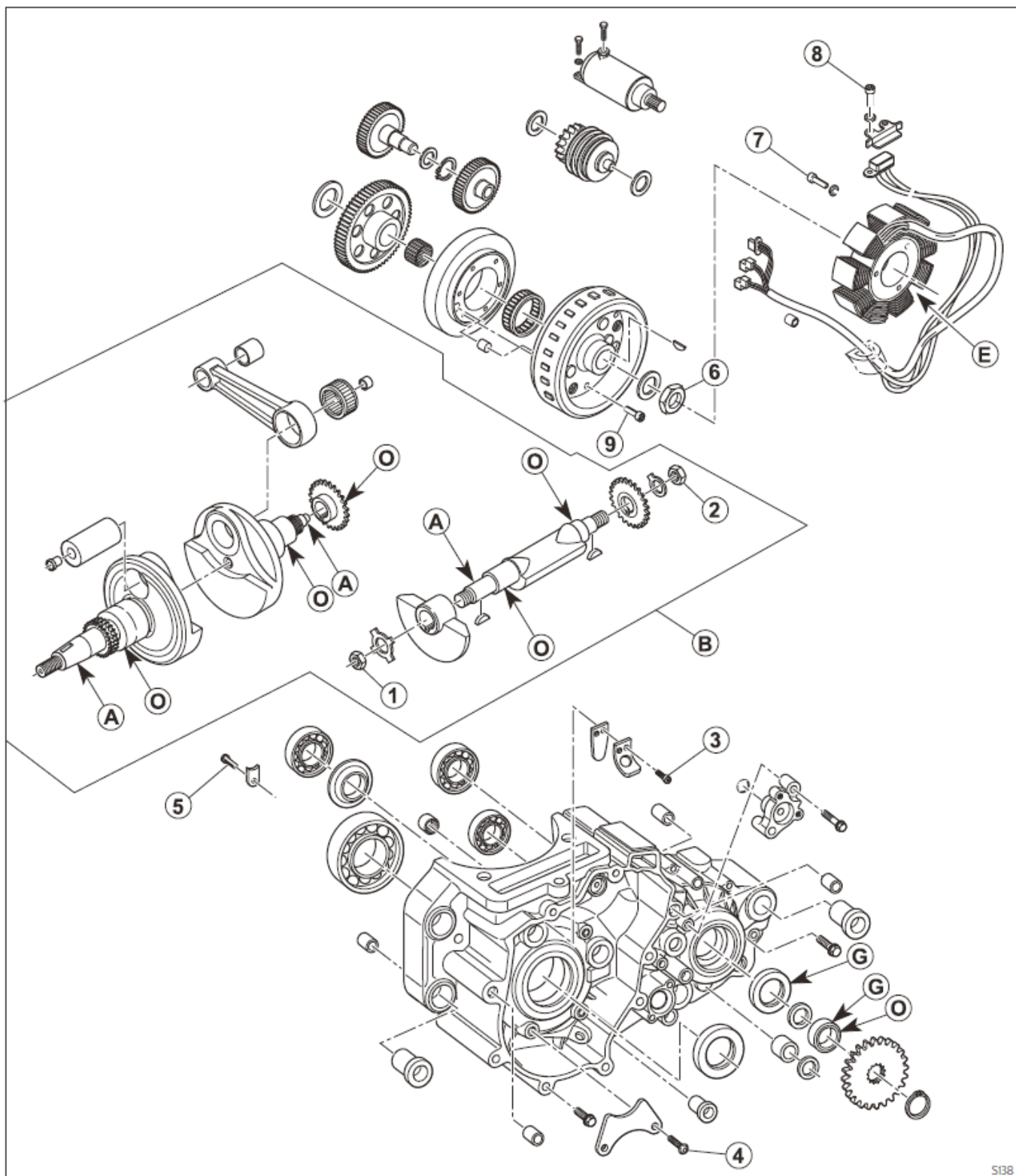

▪ **Tightening torque figures:**

1	M18 x 1.25	70 Nm (7.2 Kgm- 51.63 ft/lb)
2	M16 x 1.25	70 Nm (7.2 Kgm- 51.63 ft/lb)
3	M4 x 4.07 (+Loctite 243)	3 Nm (0.3 Kgm- 2.21 ft/lb)
4	M5 x 0.8	8 Nm (0.8 Kgm- 5.90 ft/lb)
5	M5 x 0.8 (+Loctite 243)	8 Nm (0.8 Kgm- 5.90 ft/lb)
6	M16 x 1.25	130 Nm (13.2 Kgm- 95.88 ft/lb)
7	M6 x 1 (+Loctite 270)	8 Nm (0.8 Kgm- 5.90 ft/lb)
8	M4 x 0.7 (+Loctite 272)	3 Nm (0.3 Kgm- 2.21 ft/lb)
9	M6 x 1 (+Loctite 270)	20 Nm (2 Kgm- 14.75 ft/lb)

▪ **Lubrication Notes:**

Lubrication Points-Notes	Lubricant - Installation Instructions
A	Degrease
B	Apply engine oil on installation
E	Line up stator mark with cover mark
G	WATER RESISTANT grease
O	Engine oil

Assembly and Lubrication Instructions

- Gearbox - Gear Shift Control

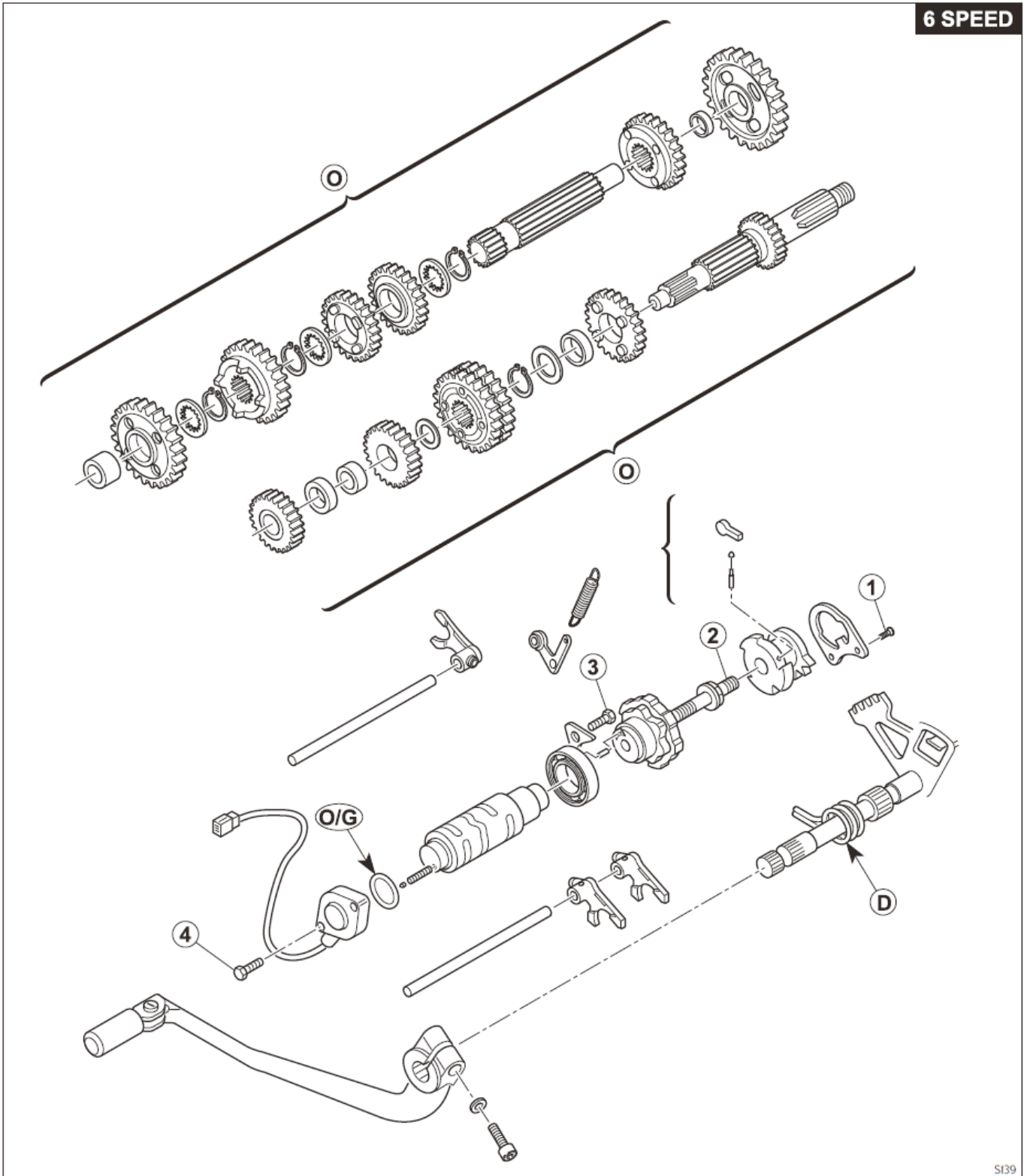

▪ **Tightening torque figures:**

1	M6x1	10 Nm (1.02 Kgm- 7.38 ft/lb)
2	M8 x 1.25 (+LOCTITE 243)	28 Nm (2.85 Kgm- 20.65 ft/lb)
3	M6 x 1 (+LOCTITE 243)	9 Nm (0.92 Kgm- 6.64 ft/lb)
4	M5 x 0.8 (+LOCTITE 243)	8 Nm (0.8 Kgm- 5.90 ft/lb)

▪ **Lubrication Notes:**

Lubrication Points-Notes	Lubricant - Installation Instructions
D	Install with open end pointing to engine centre
O	Engine oil
O/G	Engine oil or WATER RESISTANT grease

### Assembly and Lubrication Instructions

- Clutch - Kick Start - Lubrication - Right Crankcase Half

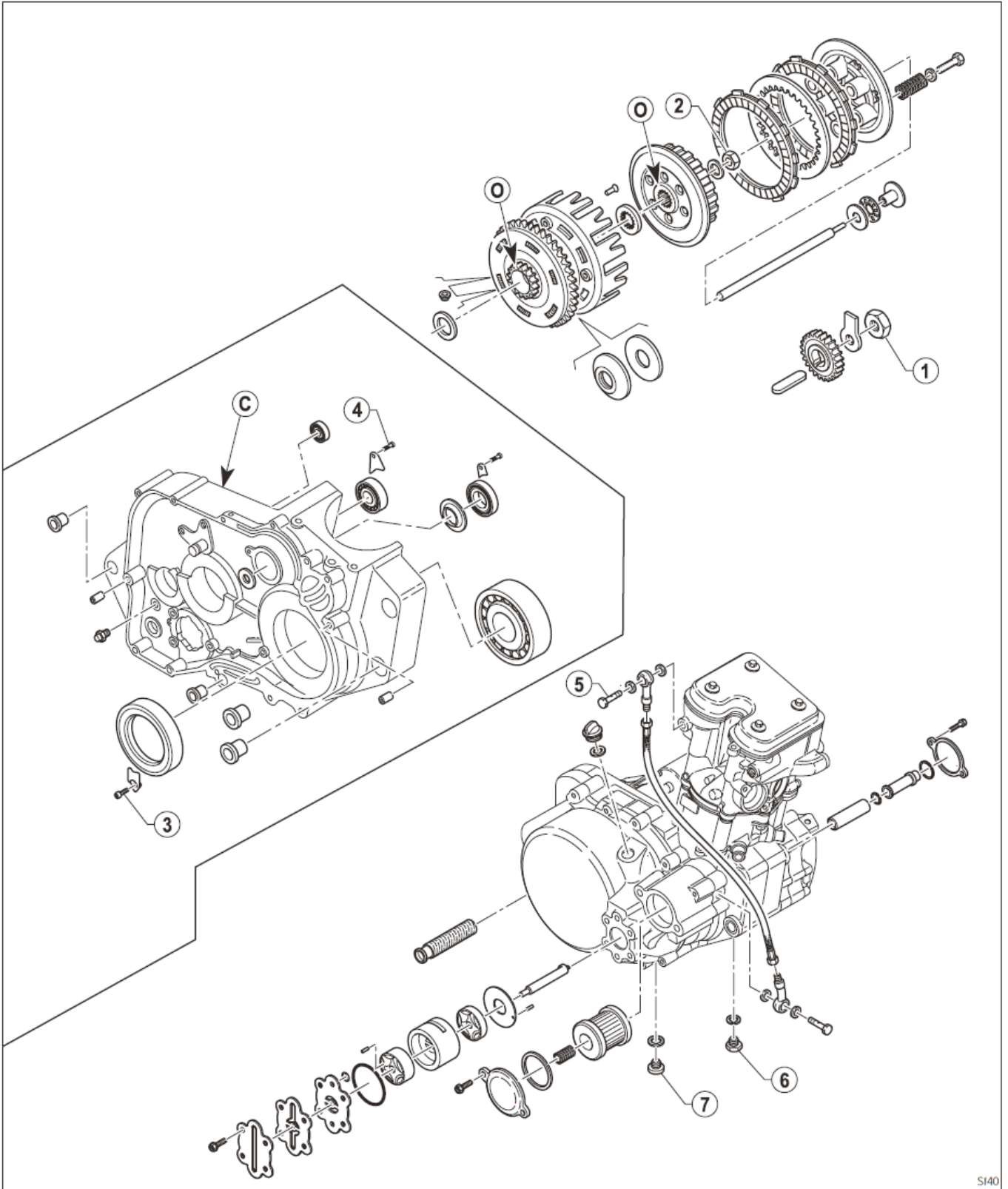

▪ **Tightening torque figures:**

1	M24x1.25 (+LOCTITE 243)	100 Nm (10.2 Kgm- 73.76 ft/lb)
2	M18x1	61.7 Nm (6.3 Kgm- 45.73 ft/lb)
3	M6x1 (+LOCTITE 243)	9 Nm (0.92 Kgm- 6.64 ft/lb)
4	M6x1 (+LOCTITE 243)	9 Nm (0.92 Kgm- 6.64 ft/lb)
5	M10x1	15 Nm (1.5 Kgm- 3.69 ft/lb)
6	M14x1.5	24 Nm (2.45 Kgm- 17.70 ft/lb)
7	M22x1.5	30 Nm (3 Kgm- 22.13 ft/lb)

▪ **Lubrication Notes:**

Lubrication Points-Notes

Lubricant - Installation Instructions

D

Engine oil

C

Join crankcase halves using Loctite 5205



### Assembly and Lubrication Instructions

- Head - Cylinder - Piston - Timing System - Water Pump - Spark Plug

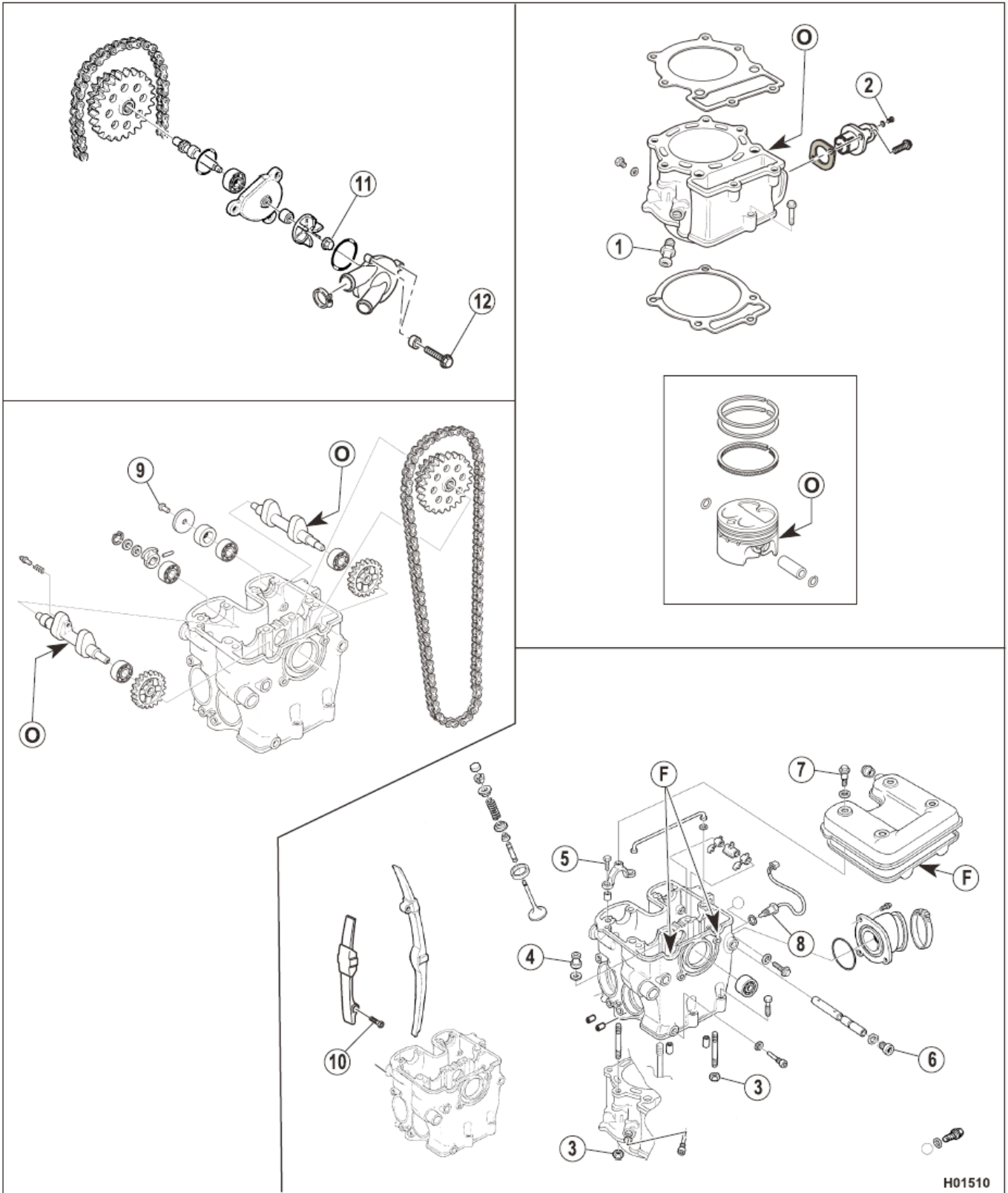

H01510

▪ **Tightening torque figures:**

1	M14x1.5 (+LOCTITE 542)	25 Nm (2.55 Kgm - 18.44 ft/lb)
2	M6x1	5 Nm (0.5 Kgm - 3.69 ft/lb)
3	M8x1.25	15 Nm (1.5 Kgm - 11.6 ft/lb)
4	M10x1.5 (MOLIKOTE HSC -COPPER GREASE)	37 Nm +90° (3.8 Kgm +90° - 27.29 ft/lb+90°)
5	M6x1	12 Nm (1.2 Kgm - 8.85 ft/lb)
6	M14x1.5 (+LOCTITE 243)	25 Nm (2.55 Kgm - 18.44 ft/lb)
7	M6x1	8 Nm (0.8 Kgm - 5.9 ft/lb)
8	M10x1.25 (ENGINES WITH ELECTRONIC INJECTION)	15±1 Nm (1.5±1 Kgm - 11.06 ft/lb)
9	M6x1 (+LOCTITE 243)	8 Nm (0.8 Kgm - 5.90 ft/lb)
10	M8x1.25	12 Nm (1.23 Kgm - 8.85 ft/lb)
11	M5x0.8 (+LOCTITE 243)	6 Nm (0.6 Kgm - 4.43 ft/lb)
12	M6x1 (+LOCTITE 542)	8 Nm (0.8 Kgm - 5.90 ft/lb)

▪ **Lubrication Notes:**

Lubrication Points-Notes

Lubricant - Installation Instructions

F	Use sealant "AREXONS RHODORSEAL 5552" on installation
O	Engine oil

## Crankshaft assembly

- Clean the oil galleries thoroughly. Lubricate the crank pin (1) with engine oil and insert it into the flywheel half (2).

WARNING

Match the oil passage holes Fig. "A".

- Fit the needle roller bearing (3) and lubricate it the engine oil. Install the connecting rod (4) and the second flywheel half (5) and align the two flywheel halves using a square.

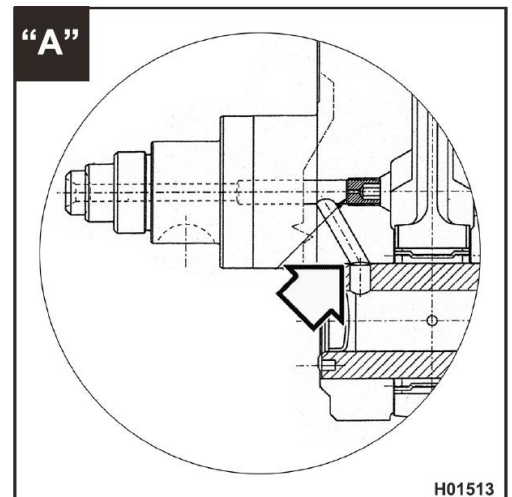
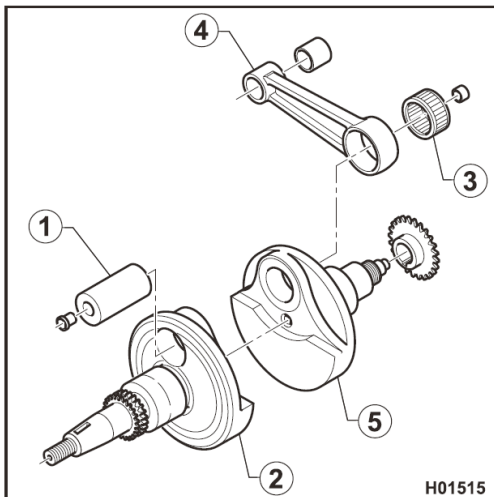
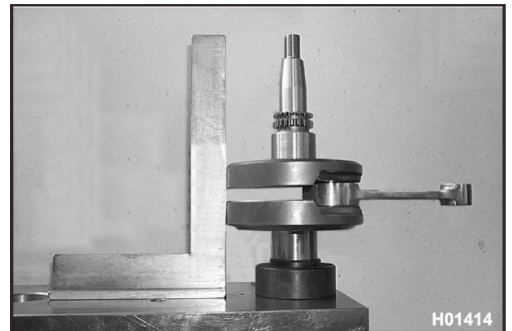
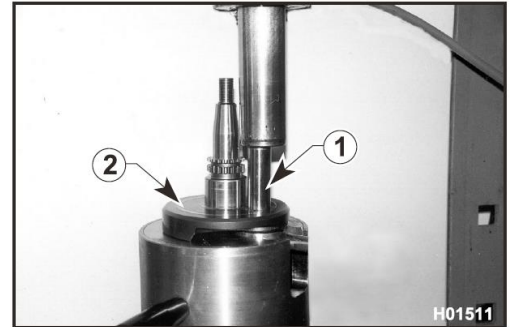

- Finally, join the parts using a press.
- Make sure the pin does not protrude at either ends as you join the flywheel halves. Observe mounting dimension "A" and set crank pin (1) at distance "B" on the right flywheel half.
- A = 6.35 - 64.45 mm (2.574-2.578 in.)
- B = 0.9 - 1.1 mm (0.036 - 0.044 in.)

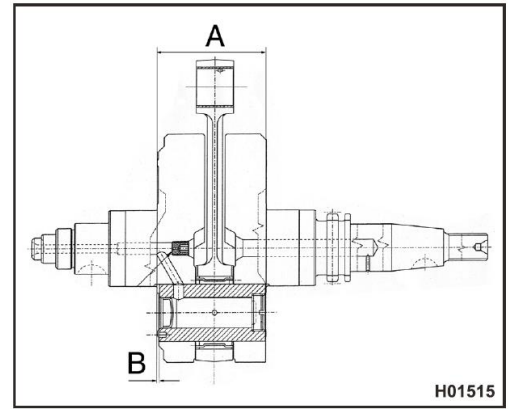

- Measure axial clearance "D" of connecting rod to flywheels; it should be 0.45-0.7 mm (0.018-0.03 in.).

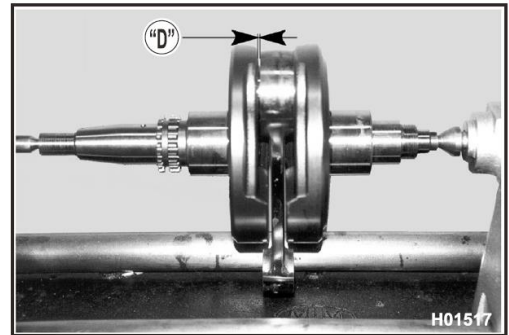

- Measure crankshaft run-out at the bearing locations "C". Run-out must not exceed 0.03 mm (0.0012 in).
- Straighten the crankshaft using a copper hammer.

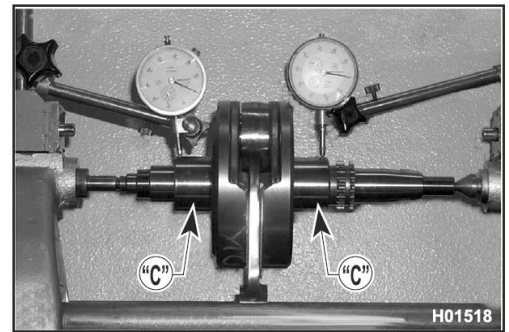

- Input shaft

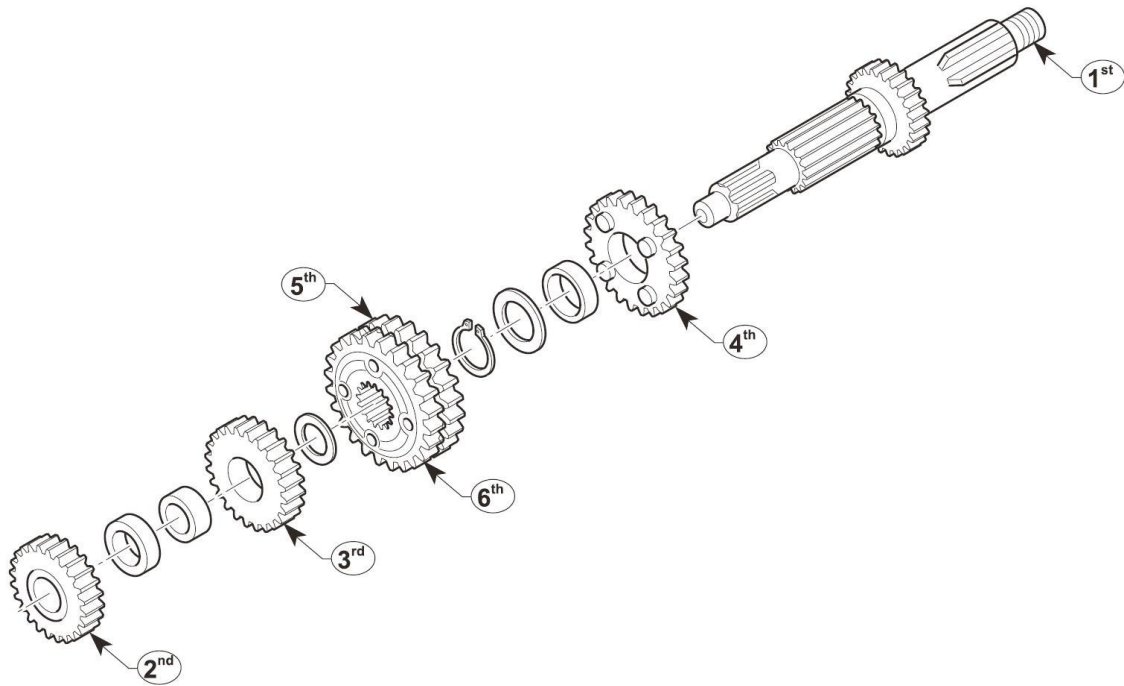

- Output shaft

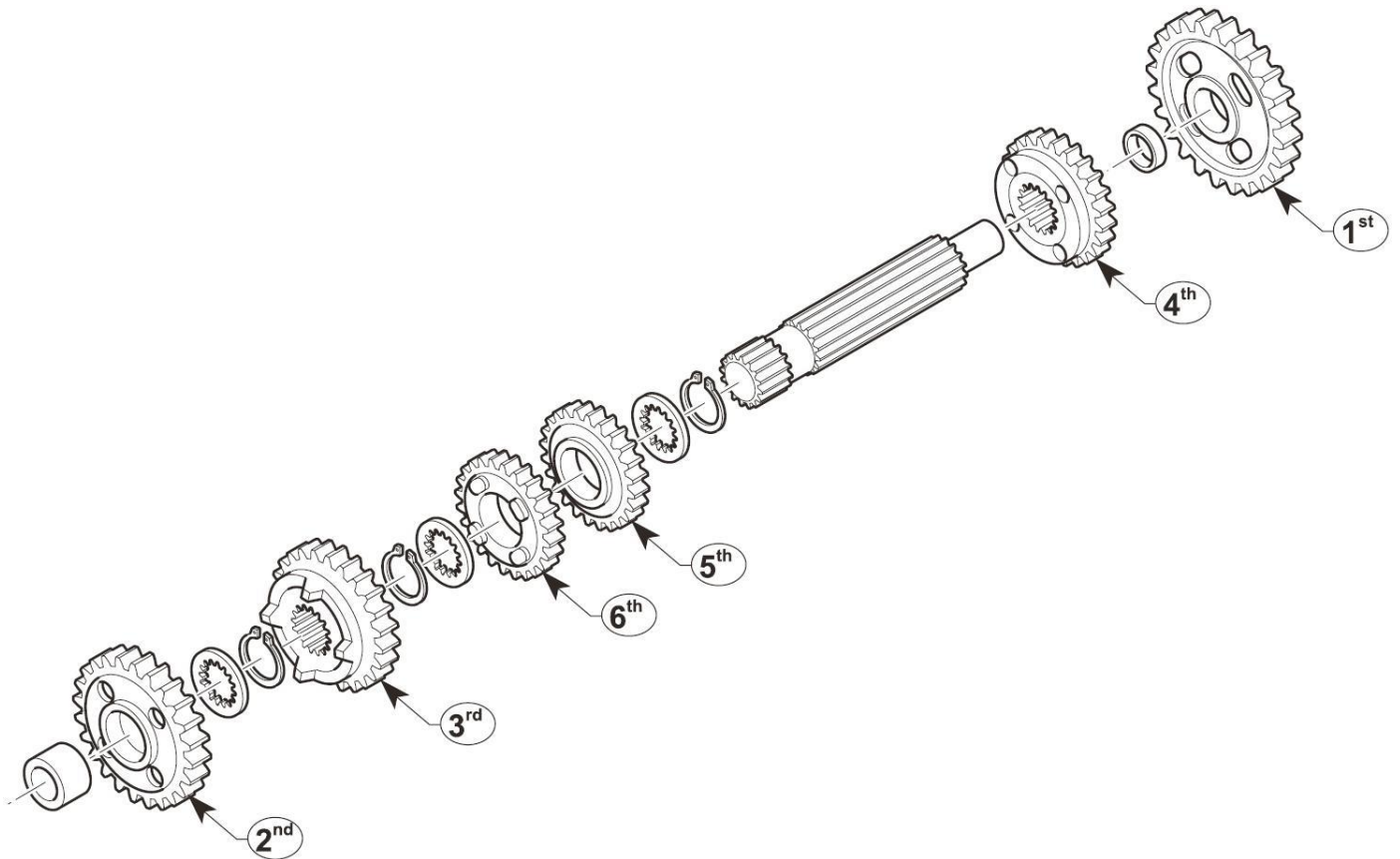

## Input shaft

- Fit bushing (2) to the input shaft (1). Lubricate inner and outer face with Molikote G-n plus grease (or equivalent) before installation.
- Fit 4<sup>th</sup> gear (3), washer (4) and retaining ring (5) with the rounded edges of washer and retaining ring facing the gear.
- Fit 5<sup>th</sup>/6<sup>th</sup> sliding gear (6).
- Fit washer (7) with the rounded edge facing the gear.
- Fit plain bearing (8). Lubricate inner and outer face with Molikote G-n plus grease (or equivalent) before installation.
- Fit 3<sup>rd</sup> gear (9).
- Fit spacer (10) and 2<sup>nd</sup> gear (11).

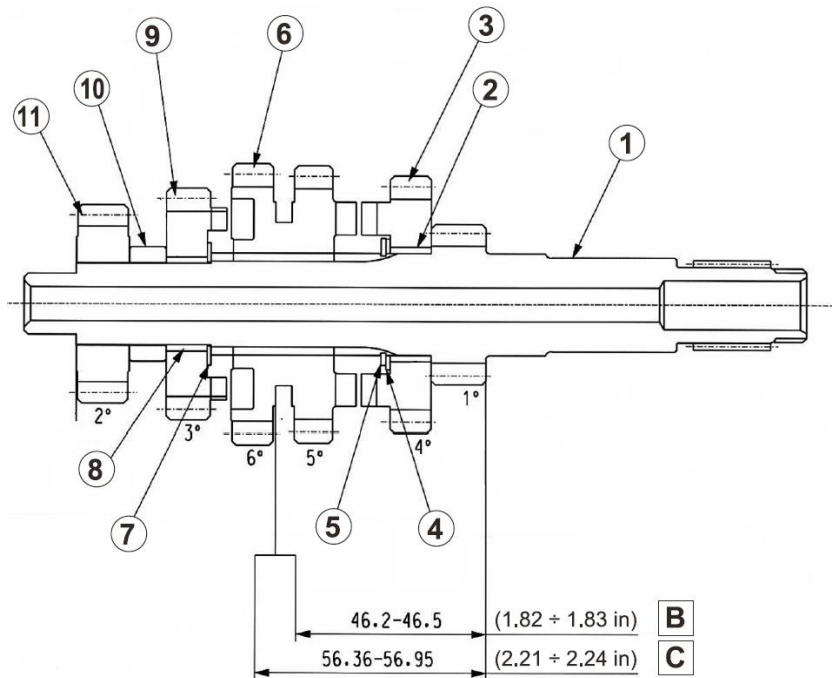

- B: Control dimension with 4<sup>th</sup> gear engaged.
- C: Control dimension with 3<sup>rd</sup> gear engaged.

Gear	Number of teeth
1 <sup>st</sup>	13
2 <sup>nd</sup>	16
3 <sup>rd</sup>	20
4 <sup>th</sup>	22
5 <sup>th</sup>	23
6 <sup>th</sup>	25

## Output shaft

- Fit bushing (2) to the output shaft (1). Lubricate inner and outer face with Molikote G-n plus grease (or equivalent) before installation.
- Fit 2<sup>nd</sup> gear with the splined side facing 3<sup>rd</sup> gear.
- Fit washer (4) and retaining ring (5) with the rounded edges of washer and retaining ring facing the gear.
- Fit 3<sup>rd</sup> gear (6) as shown.
- Fit retaining ring (7) and washer (8) with the rounded edges of washer and retaining ring facing the gear.
- Fit 6<sup>th</sup> gear (9).
- Fit 5<sup>th</sup> gear (10).
- Fit washer (11) and retaining ring (12) with the rounded edges of washer and retaining ring facing the gear.

**NOTE:** 5th and 6th gears should turn freely against each another.

- Fit 4<sup>th</sup> gear (13) with the flange facing 5<sup>th</sup> gear.
- Fit bushing (14) to the input shaft (1). Lubricate inner and outer face with Molikote G-n plus grease (or equivalent) before installation.
- Fit 1<sup>st</sup> gear (15) with the bevelled edge facing 4<sup>th</sup> gear.

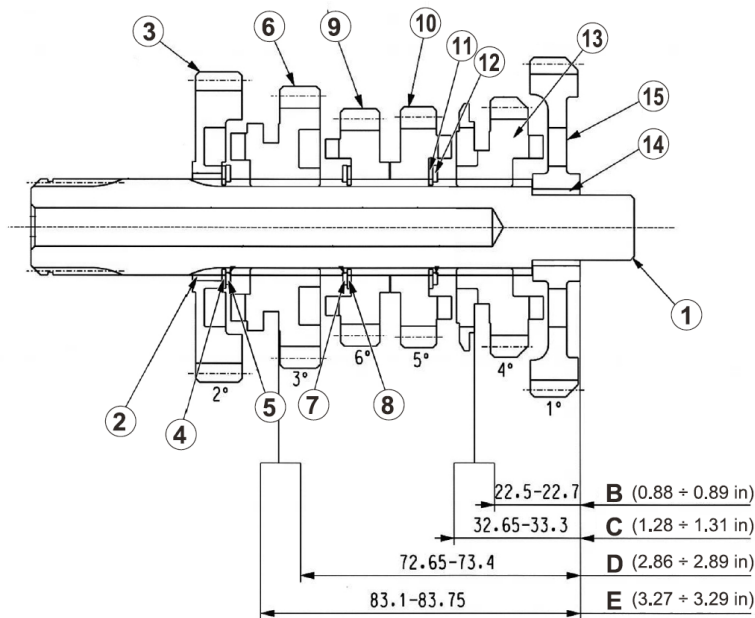

- B: Control dimension with 1st gear engaged
- C: Control dimension with 5th gear engaged
- D: Control dimension with 6th gear engaged
- E: Control dimension with 2nd gear engaged

Gear	Number of teeth
1 <sup>st</sup>	34
2 <sup>nd</sup>	29
3 <sup>rd</sup>	27
4 <sup>th</sup>	24
5 <sup>th</sup>	22
6 <sup>th</sup>	22

## Crankcase assembly

- Clean the crankcase half mating faces and place crankcase half on tool.

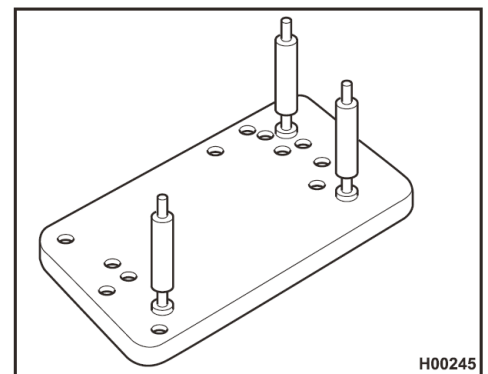

- Heat up to around 125 °C and drive the ball bearings into each crankcase half using a suitable driver tool.

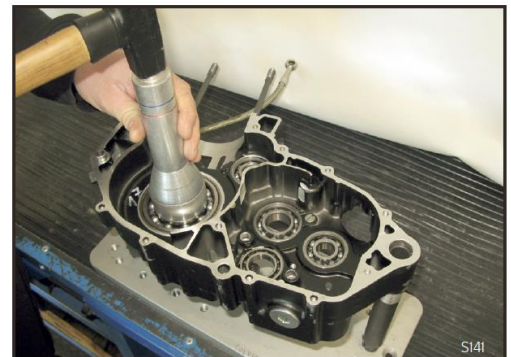

- Fit the retaining plates (1) and (2) to the crankcase bearings.

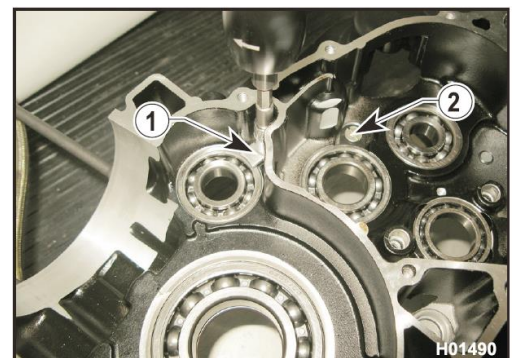



- Install the input and output shaft assembly pushing them fully home into the right crankcase half and make sure input (3) and output shaft (4) gears are flush.

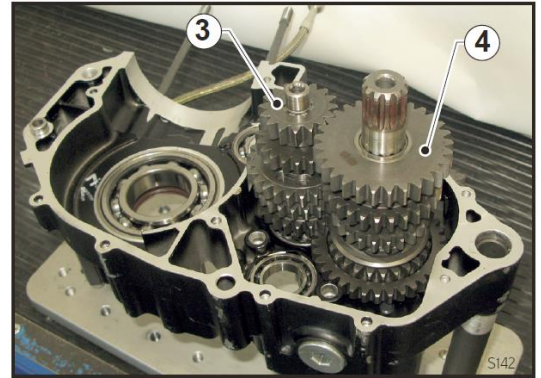

- Lubricate the shifter forks (5) with engine oil and install them.

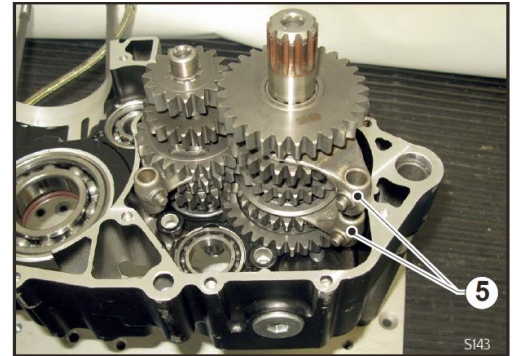

- Insert the selector drum (6) into its seat.

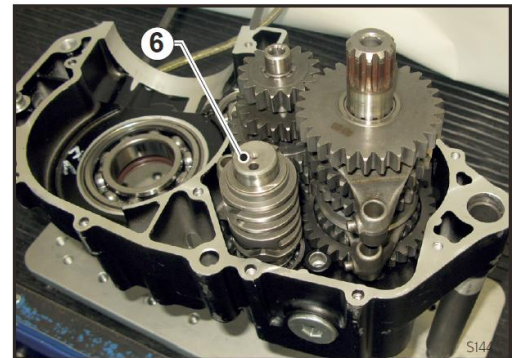

- Install the fork shafts (7) and (8) and make sure the forks move freely.
- Make sure the fork pins (9) are correctly located in the drum grooves (6).
- Rotate the selector drum to test operation.

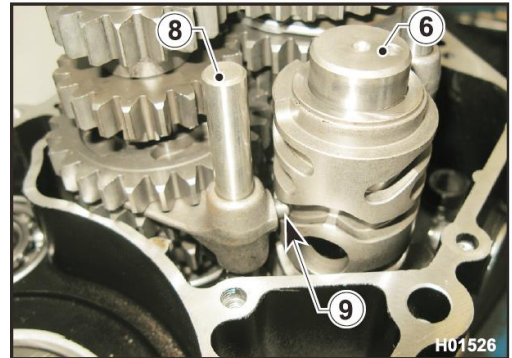
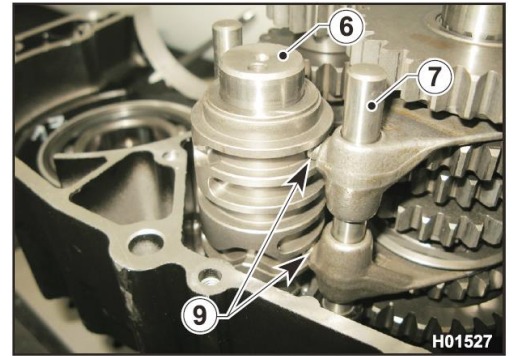

- Heat up the crankshaft bearing (10) and install the crankshaft (11).
- Fit the countershaft (12) onto its bearing.

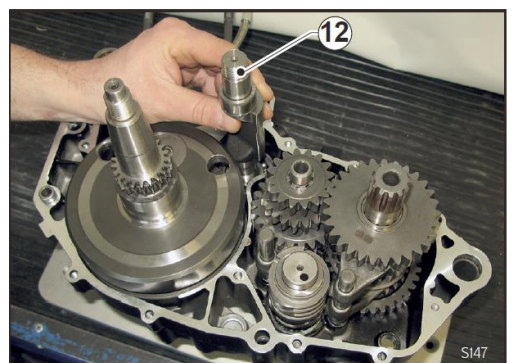
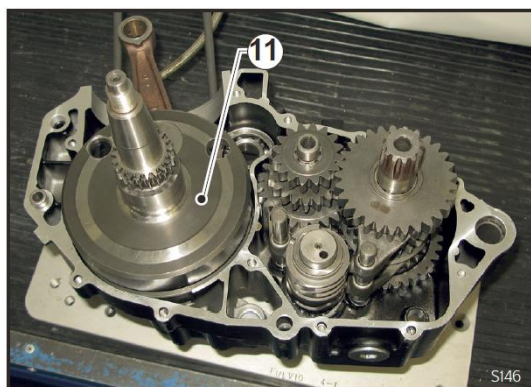
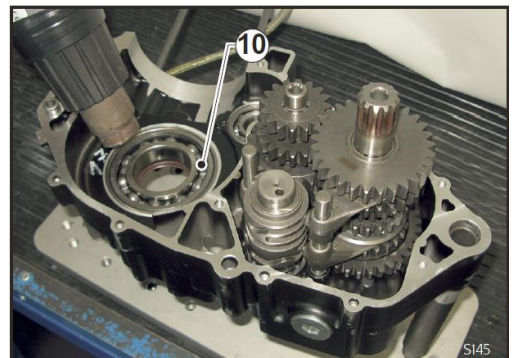

- Make sure both crankcase locating bushings (13) are in place.
- Apply a layer of “LOCTITE 5205” on the right crankcase mating surface (14).

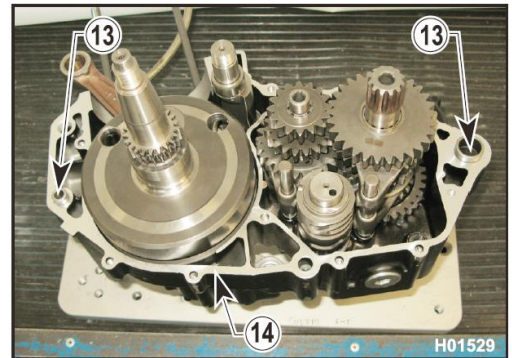

- Heat up the left crankcase bearing locations and install the crankcase.

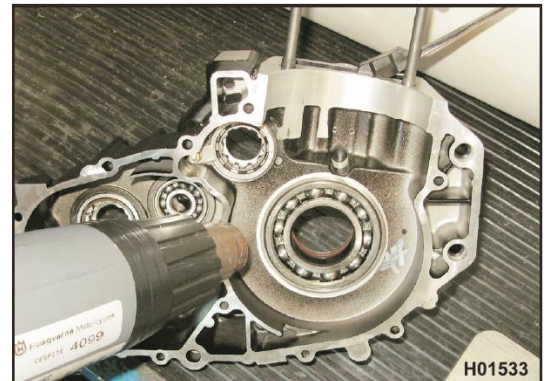

- Grease the sprocket bearing bushing (15) and fit it into the bearing; fit the left crankcase half onto the right crankcase half.

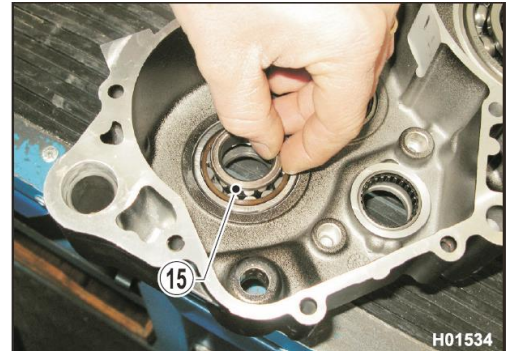

- To join the crankcase halves, tap with a plastic hammer.
- Tighten the screws (16) and make sure to fit the screws in the correct positions according the pattern shown.

- |   |
|---|
| <p>12a= M6x55 mm (2.165 in.)</p> <p>12b= M6x55 mm (2.165 in.) + copper washer</p> <p>12c= M6x55 mm (2.165 in.)</p> <p>12d= M6x65 mm (2.559 in.)</p> |
|---|

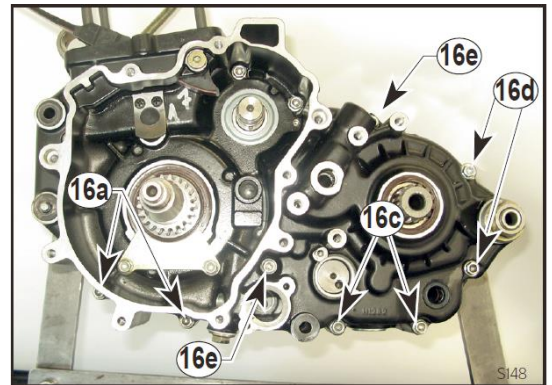

- Install mesh filters (17) and their cover (18) and tighten the screws (19).

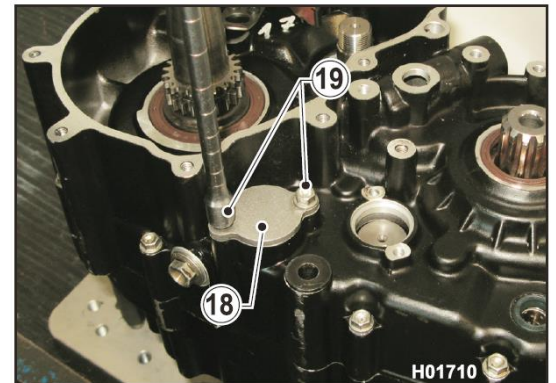
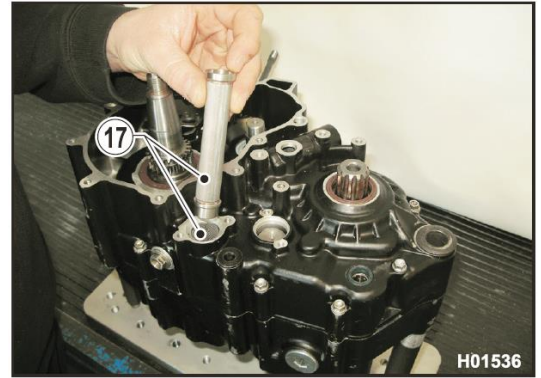

- Insert bushing (20) with its O-ring (21); the O-ring groove must be facing into the engine.

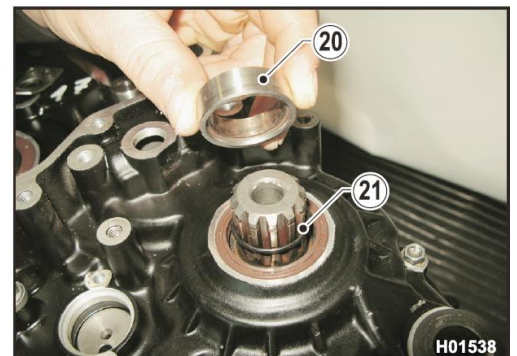

- Cover the upper section of the engine with a cloth, a sponge or the like to prevent screws or other parts from accidentally falling into the engine.

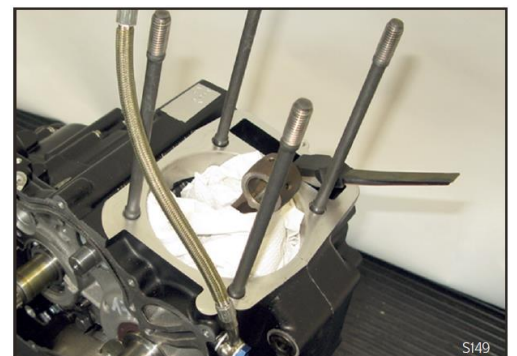

## Gear sensor installation

- Insert spring (1) and pushrod (2) into their seat (3).

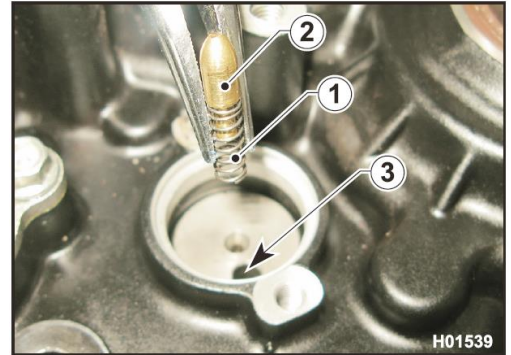

- Fit the sensor (4); make sure to install the gasket. Tighten the screws (5) 8 Nm (0.8 Kgm or 5.8 ft/lb).

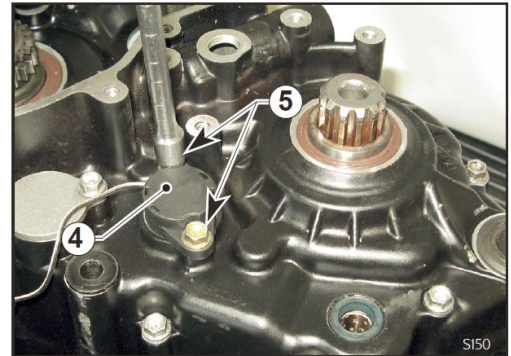

## Gear shift control assembly

- Install the ratchet (1) and tighten the screw (2); 28 Nm (2.8 Kgm or 20.65 ft/lb).

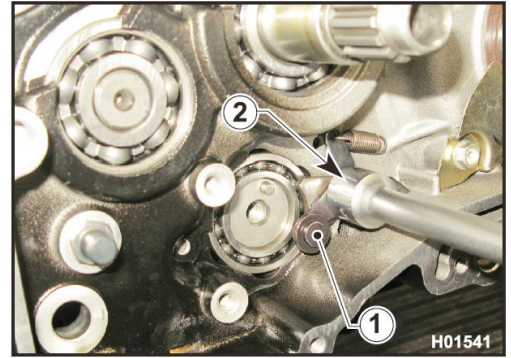

- Engage the spring (3) with the suitable pin.

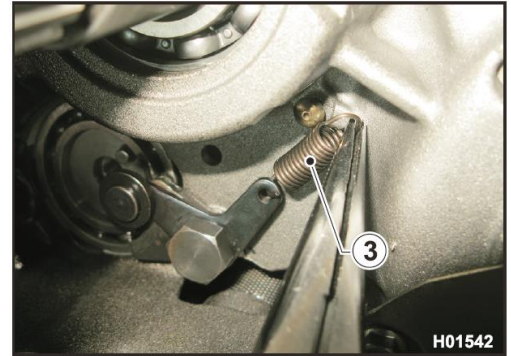

- Install the selector drum (4) making sure the tab (5) locates in the recess (6) and secure drum with its screw (7). (Apply Loctite 243, tighten to 28 Nm; 2.8 Kgm; 20.65 ft/lb).

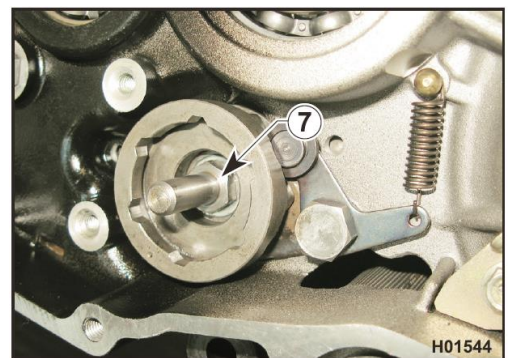
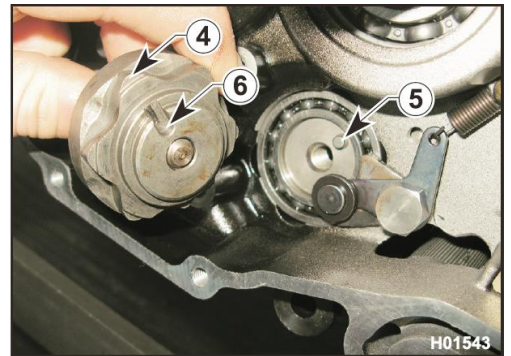

- Operate shifter and transmission shaft to test gearbox for proper operation.
- Refit the ratchet assembly (8) together with the plate, making sure ratchets and springs are in the correct positions.

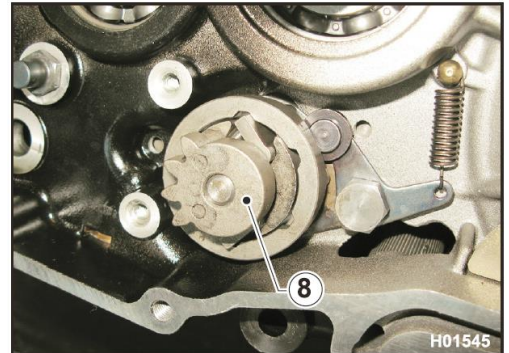
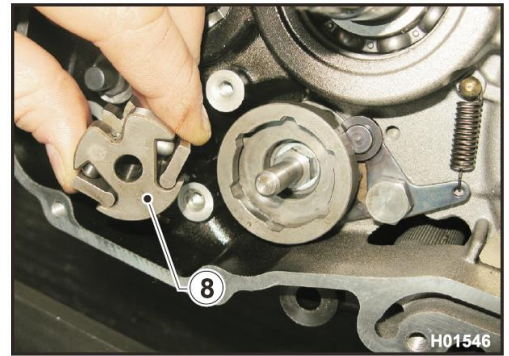

- Tighten the screws (9) of plate (10), with Loctite 243, to 9.3 Nm (0.93 Kgm or 6.85 ft/lb).

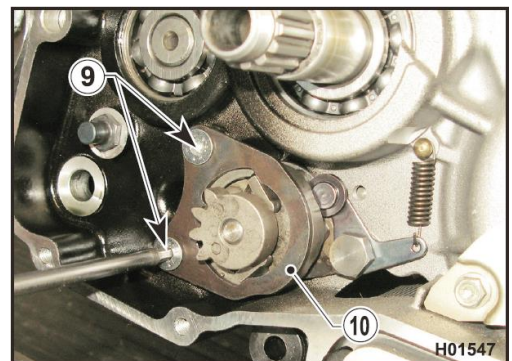

- Make sure the spring (11) of the gear shift lever shaft is positioned correctly.

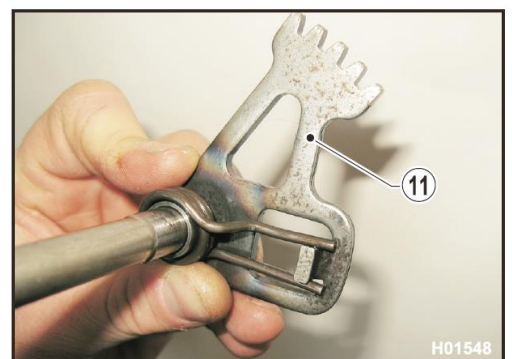



- Lubricate the shaft with engine oil and insert the shaft (12) into the crankcase so that the teeth (13) mesh with sector gear (8) teeth and spring (14) locates to its abutment pin.

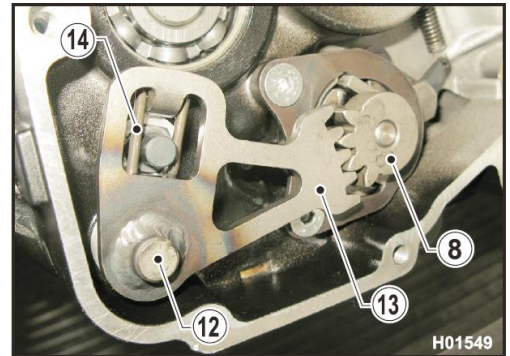

- Install the gear shift lever (15) and operate the gearbox manually (9 Nm; 0.9 Kgm; 6.64 ft/lb).

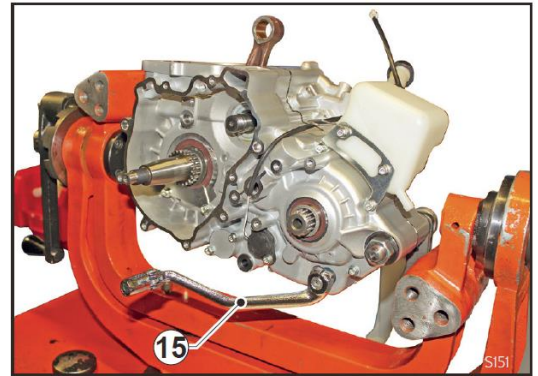

## Crankshaft gears installation

- Fit the countershaft driving gear (1) to the crankshaft with the timing dot facing out.
- Fit the input shaft driving gear (2) with the bevelled side facing out.

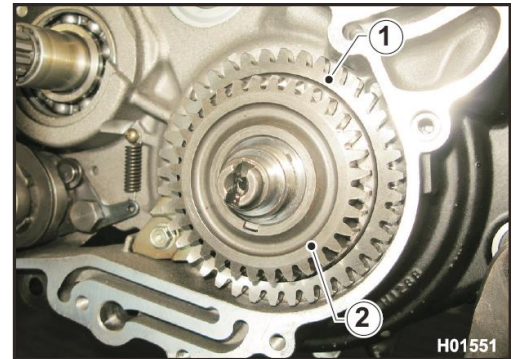

## Countershaft weight/gear installation

- Fit the countershaft gear (1) line up its dot with that of the crankshaft gear (2) to set timing.

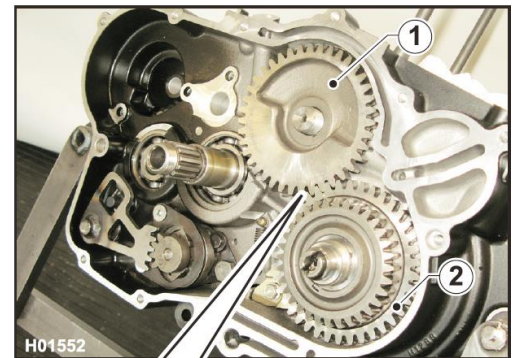

- Fit the lock washer (3) onto the gear making sure the tab locates into the keyway.

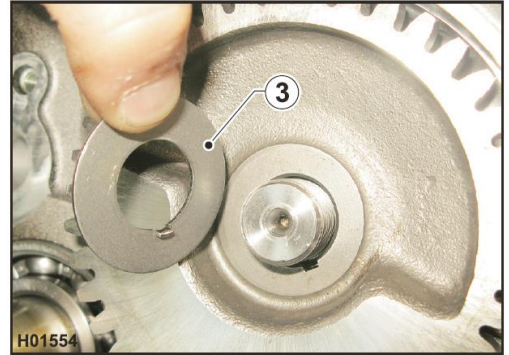

- Tighten the nut (4) to 70 Nm (7 Kgm; 51.58 ft/lb) placing an aluminium shim (5) between countershaft gear (1) and crankshaft gear (2).

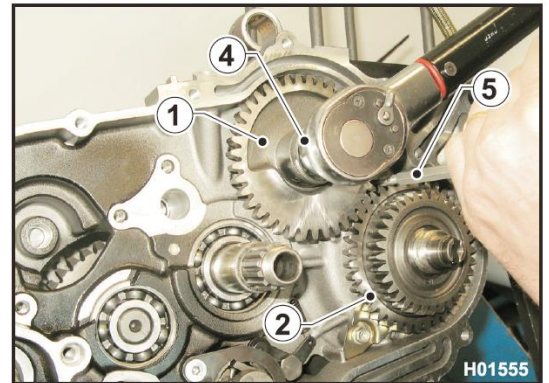

- Bend the lock washer (3).

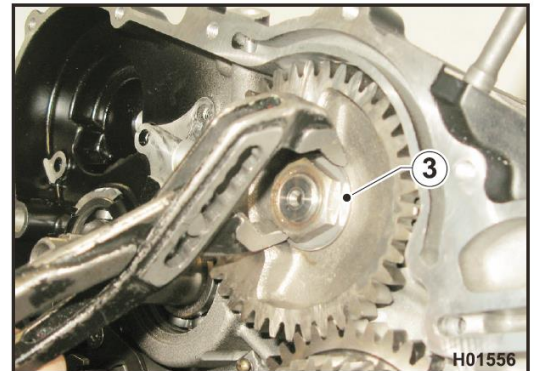

- Fit the lock washer (6) onto the crankshaft gear making sure the tab locates into the keyway.

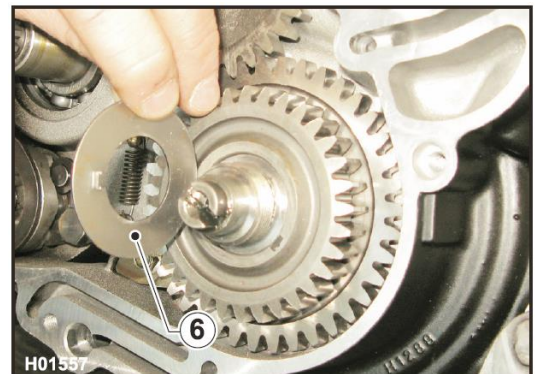

- Tighten the nut (7) to 100 Nm (10 Kgm or 73.69 ft/lb) placing a half gear (8) between countershaft gear (1) and crankshaft gear (2).

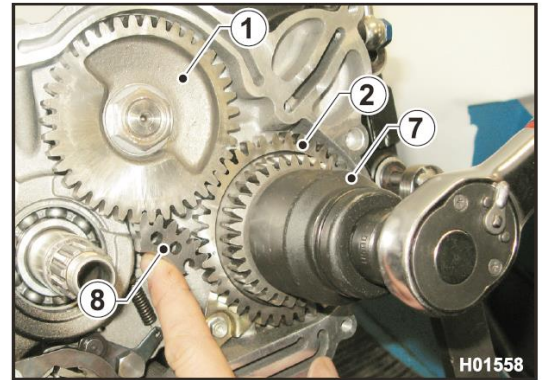

- Turn the engine over.
- Fit the counterweight (9) to the countershaft.
- Fit the lock washer (10) onto the shaft making sure the tab locates into the keyway.

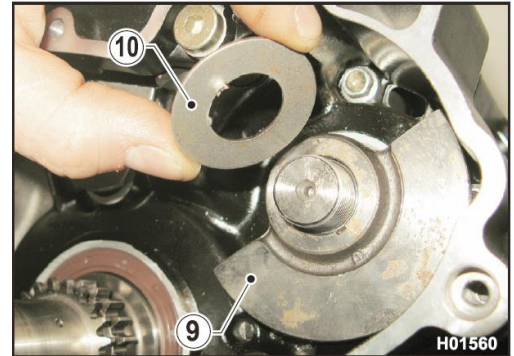

- Tighten the nut (11) to 70 Nm (7 Kgm or 51.58 ft/lb) placing a half gear at the opposite side of the engine between countershaft gear (1) and crankshaft gear (2).
- Bend the lock washer (10).

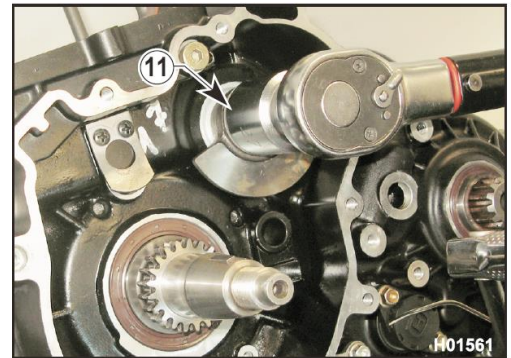

## Clutch assembly

- Slide washer (1) and bushing (2) over the shaft (lubricate with engine oil).

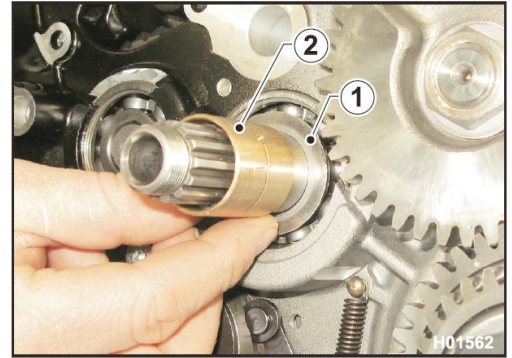

- Lubricate the shaft with engine oil and fit the clutch housing (3).

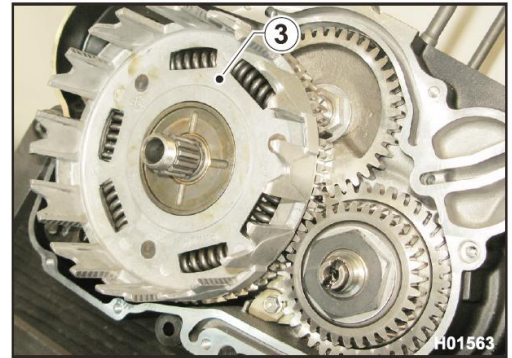

- Fit the splined spacer (4).

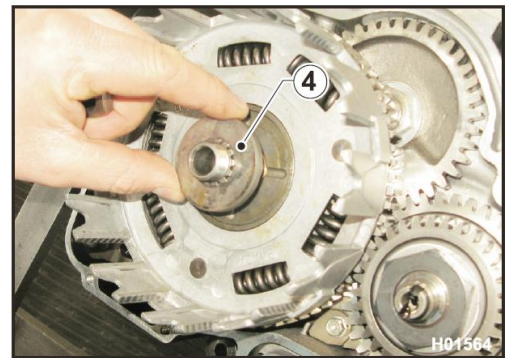

- Fit the clutch hub (5) and its lock washer (6).

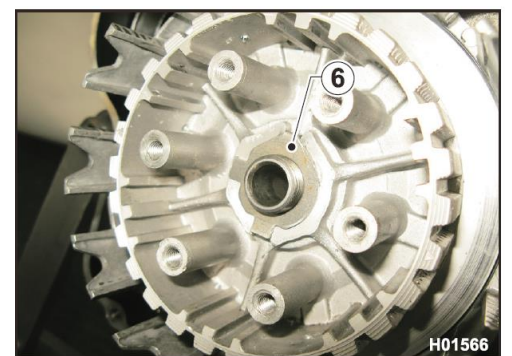
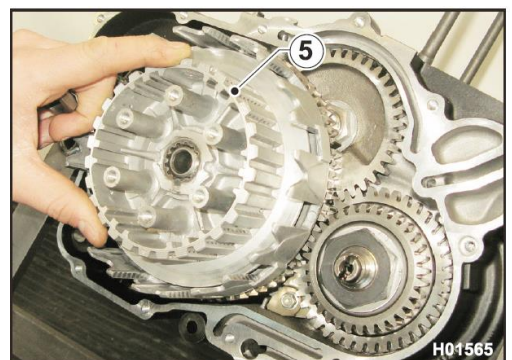

- Use the suitable tool (7) to prevent rotation and tighten the nut (8) to 61.7 Nm (6.17 Kgm or 45.47 ft/lb).

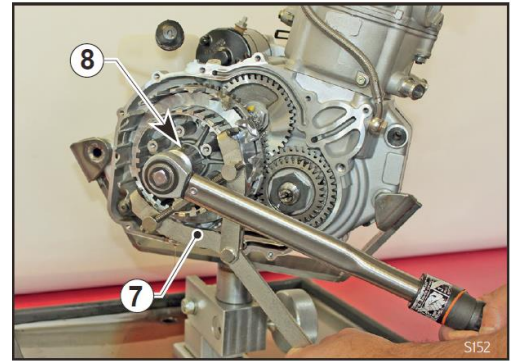

- Bend the lock washer (6).

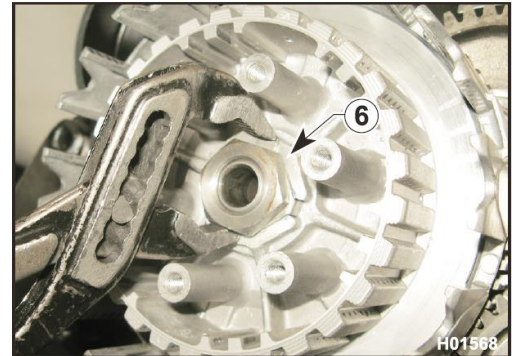

- Refit the plates (9) (install a friction plate first and then a steel plate and keep alternating between friction and steel plates; the last to go in should be a steel plate).

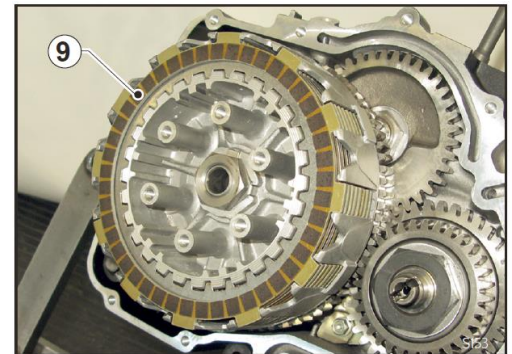

- Fit actuator plate (10), thrust bearing (11), thrust washer (12), pressure plate (13) and springs (14). Tighten the spring screws (15) gradually in a cross pattern to 5 Nm (0.5 Kgm or 3.6 ft/lb).

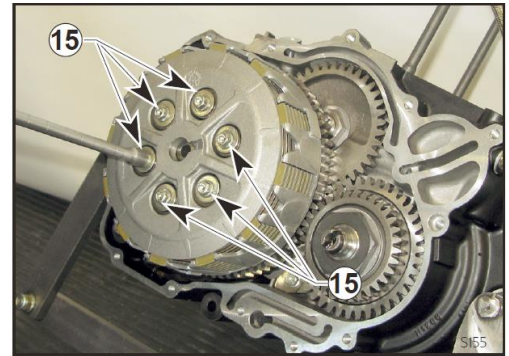
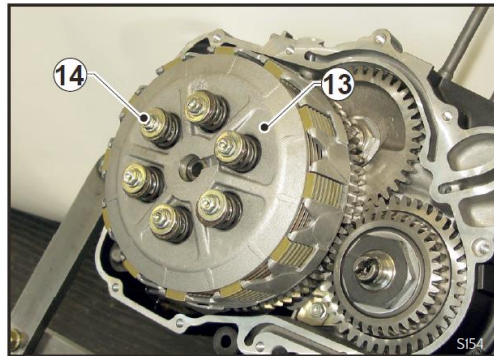
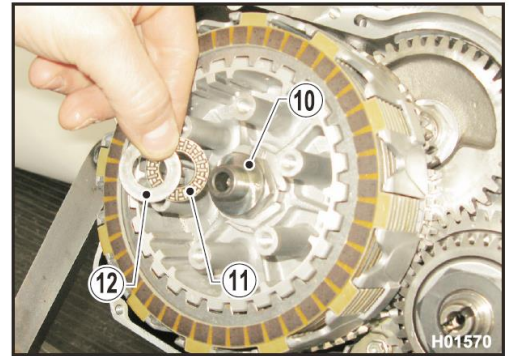

### Piston ring installation

- Fit the piston rings as shown in the diagram. If the piston ring is marked on one side, that side must be facing up.

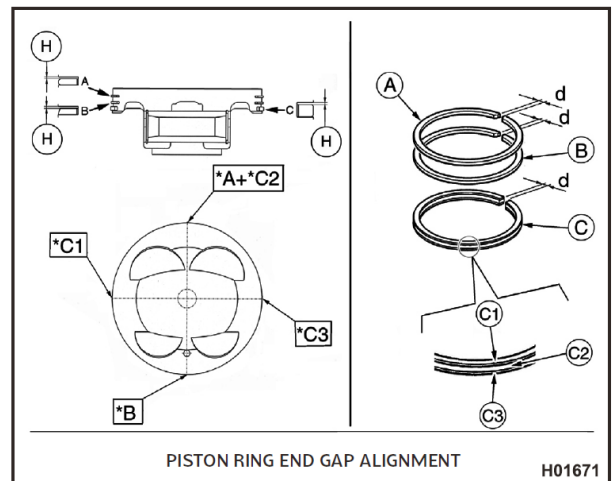

- Piston and cylinder installation
- Remove the cylinder protection (1).
- Install a new cylinder foot gasket (2).

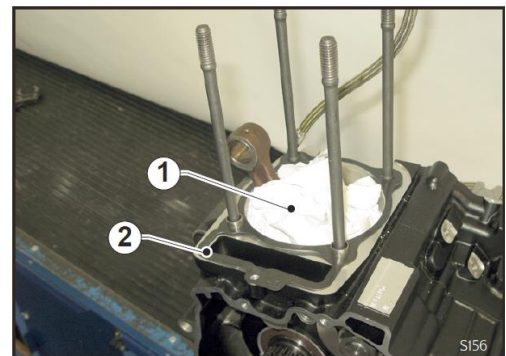

- Assemble piston (3) to connecting rod (4) (lubricate with engine oil) and fit the piston pin retaining rings (5).
- Make sure the arrow mark on the piston is pointing to the front end.

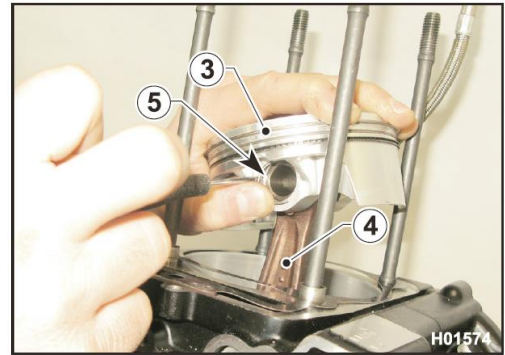

- Make sure that the locating pins (6) are in place.



- Lubricate the cylinder wall (7) with engine oil and slide it over the piston rings.
- Fit the two locating bushings (8).
- Secure the cylinder (7) to the crankcase tightening screw (9)

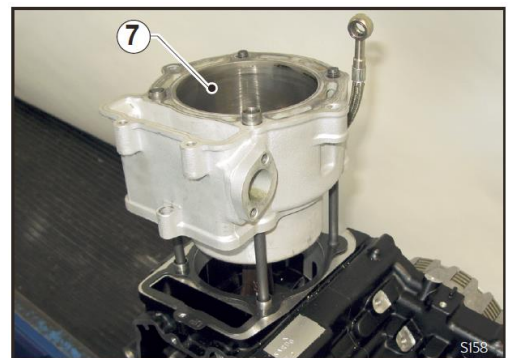
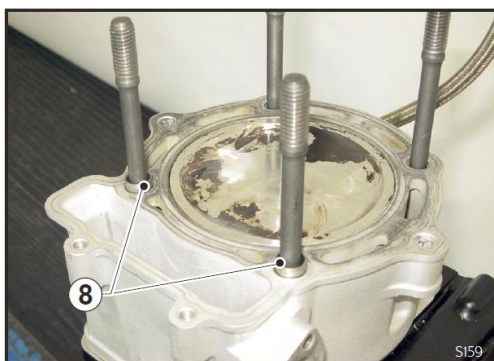
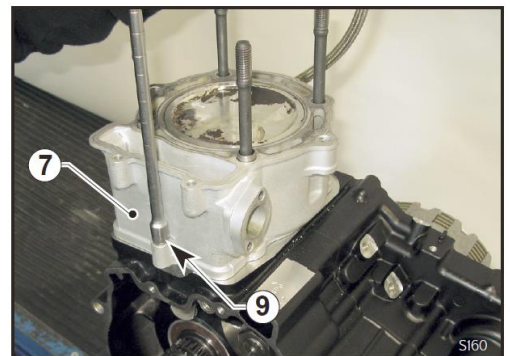



- Install the timing chain (10).

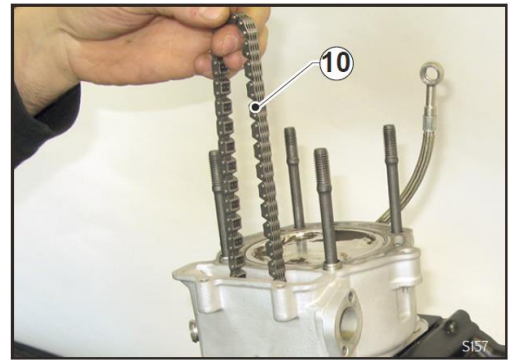

- Position the slider (11) and tighten screw (12)

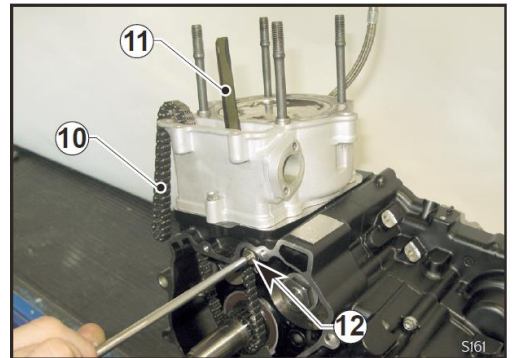

- Fit the head bolts and spacers (13) to temporarily secure the cylinder (7) in place, and tighten to 25 Nm (2.5 Kgm or 18.44 ft/lb).
- Make sure that the piston is at Top Dead Centre.
- Measure distance "A" on the two machined faces "B" of the piston and choose the appropriate head gasket according to the table.
- Remove spacers and screws (13) and fit the appropriate head gasket.

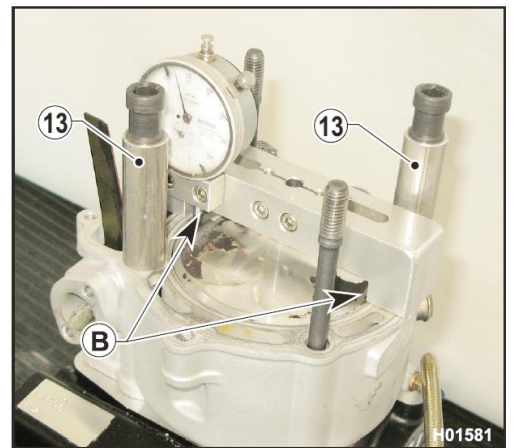

## Cylinder head gasket selection table

- Bring piston to T.D.C. at the end of the compression stroke, measure distance “A” between piston crown and head gasket mating face and select the appropriate gasket according to the table below.

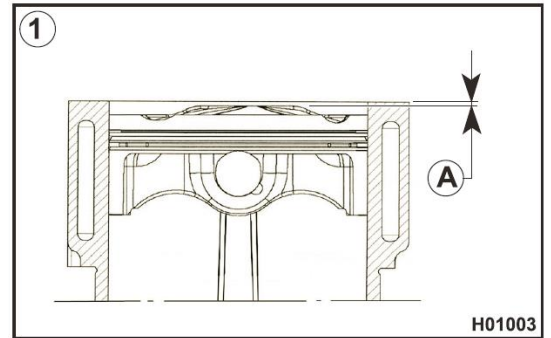

Condition (see diagram)	Dimension “A”	Gasket thickness	Gasket part no.
Piston lower than cylinder mating face	-0.4 ± 0.05 mm	1.2 mm	8000 H0937
	-0.5 ± 0.05 mm	1.1 mm	8A00 H0937
	-0.6 ± 0.05 mm	1 mm	8B00 H0937

## Cylinder head installation

- For valve installation instructions, please see Valve Installation
- Always use a new head gasket on assembly: see the "Cylinder head gasket selection table".
- Install the head (1) while supporting the timing chain (2) with a tool. Tighten the head bolts (3) gradually in a cross pattern to 38 Nm+90° (3.8 Kgm+90° or 28.03ft/lb+90°).
- Tighten the two head to cylinder nuts (4) at the sides (see Section "X" for tightening torque figures).

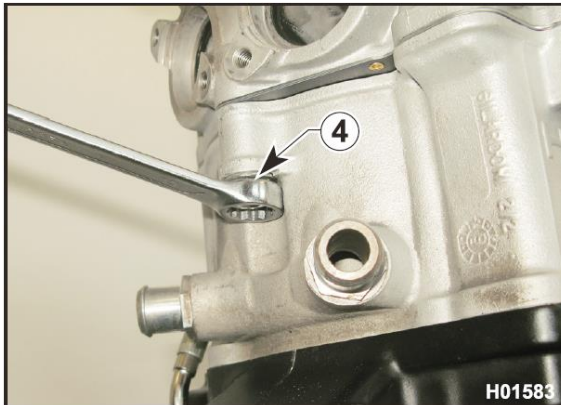
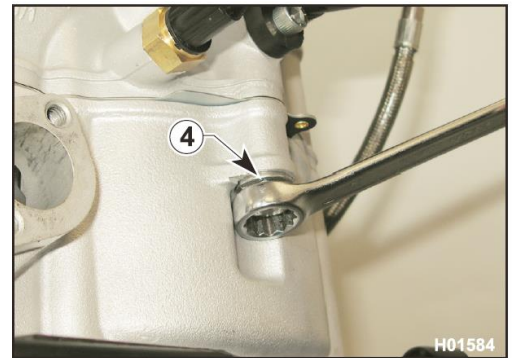
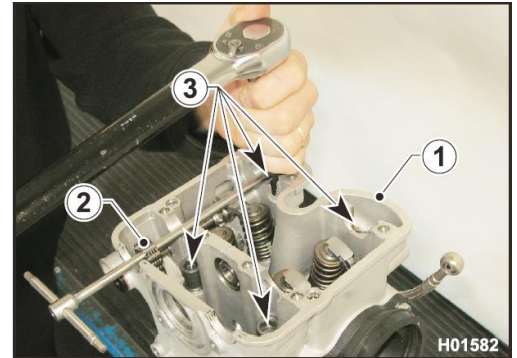

- Refit the cooling water temperature sensor (4A) and tighten to 15 Nm (1.5 Kgm or 11.6 ft/lb).

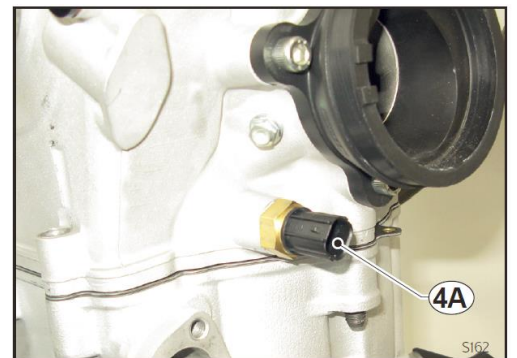

- Tighten the two head to cylinder bolts (5)

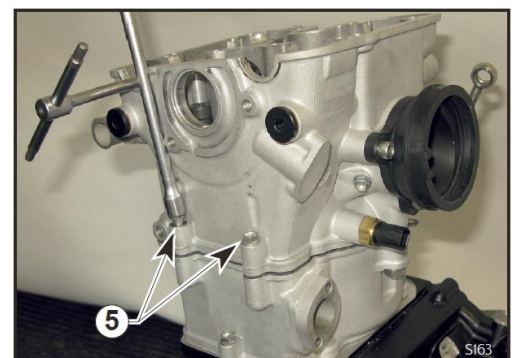

- Insert the fixed slider (6) and secure it into place tightening the retaining screw (7) (see Section "X" for tightening torque figures).

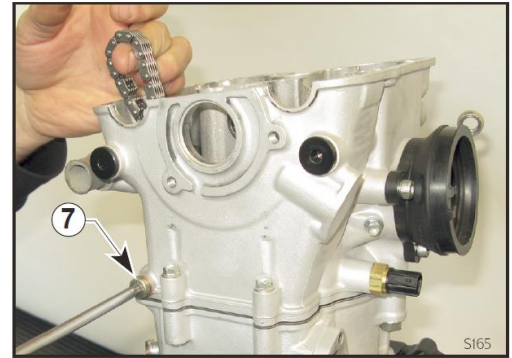
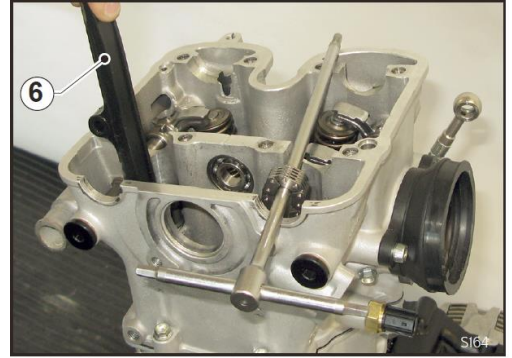

- Refit the four shims (8) on the valves as marked on removal.

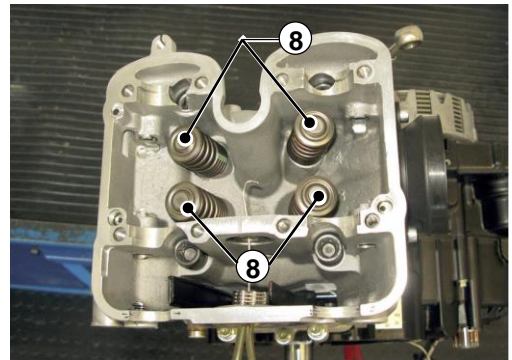

- Fit the shafts (9) of the rocker arms (10) as marked on removal with the slotted end facing outwards.
- Tighten the screws (11)
- Fit the two spring spacers (12).

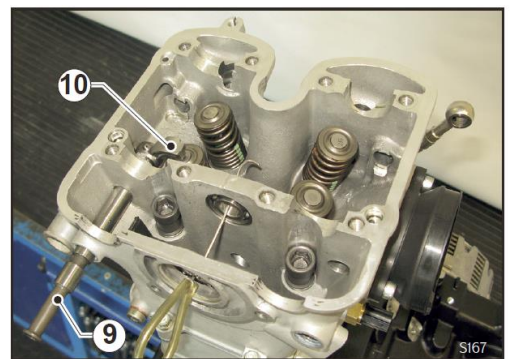

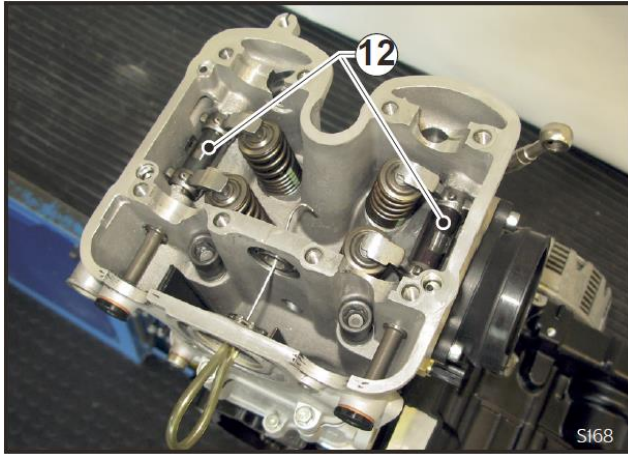

## Water pump installation

- Secure a dial gauge (1) to the spark plug hole.
- Turn the crankshaft manually until bringing the piston to Top Dead Centre.

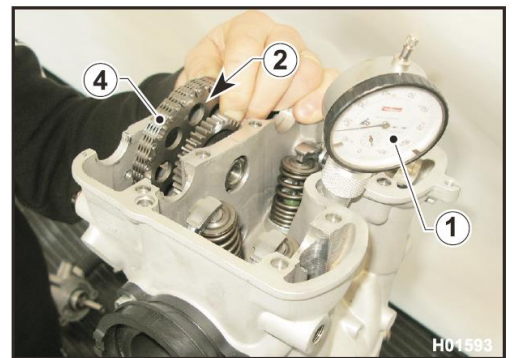

- Insert the timing drive gear (2) into the head lining up the notch on the camshaft drive gear (3) with the notch on the head mating face.
- Install the chain on the gear (4).

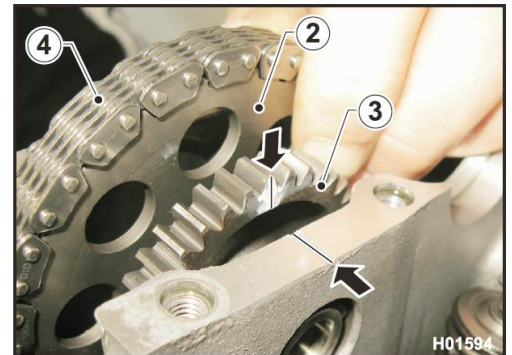

- Fit the water pump (5) to the head; check the O-ring (6) for damage.
- Tighten the screws (7) to 8 Nm (0.8 Kgm or 5.8 ft/lb) + Loctite 542.
- Connect the rubber hose (8) and tighten the clamp (9).

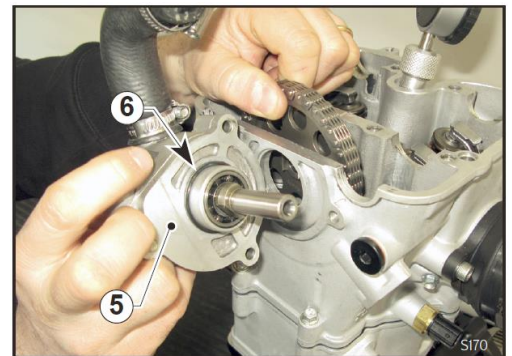

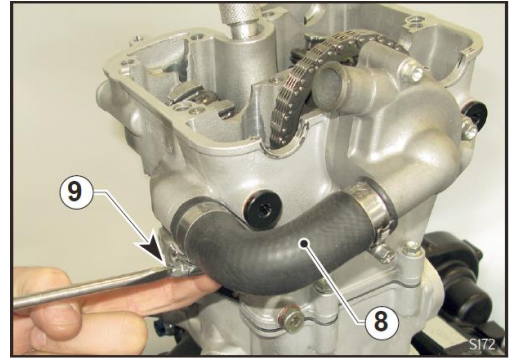
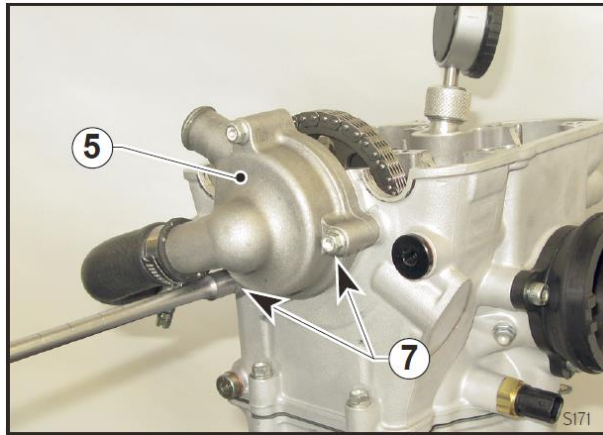

## Timing chain tensioner installation

- Refit the chain tensioner (1) and its gasket. Tighten the two screws (2) to 10 Nm (1.0 Kgm or 7.25 ft/lb).
- Release the chain tensioner (1) using a screwdriver (turn counter clockwise).

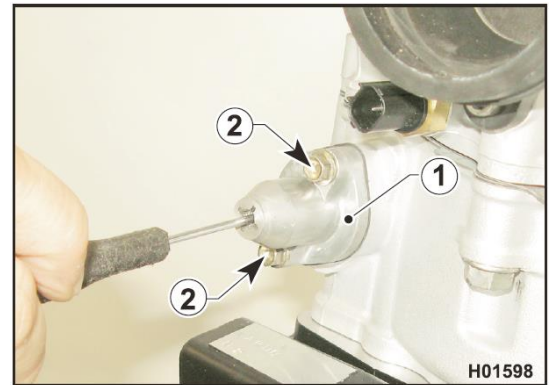

- Refit the screw (3) with its washer.

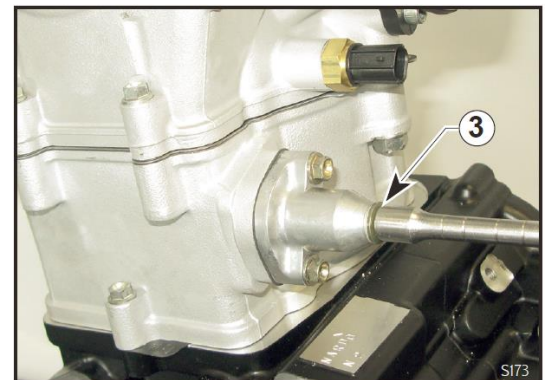

## Camshaft installation

- Secure a dial gauge (1) to the spark plug hole.
- Turn the crankshaft manually until bringing the piston to Top Dead Centre.
- Insert the camshaft drive gear (2) into the head lining up the dot on gear (3) with the head mating face. Make sure the dot on the inboard side of gear (3) is lined up with the dot on the left of the timing gear (4).

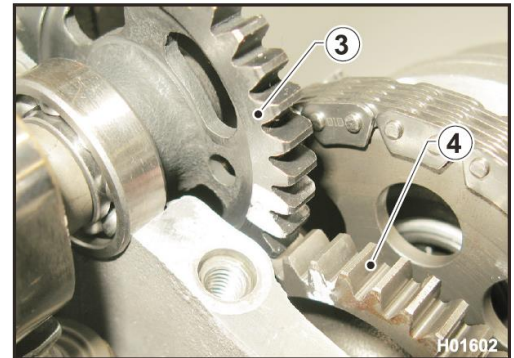
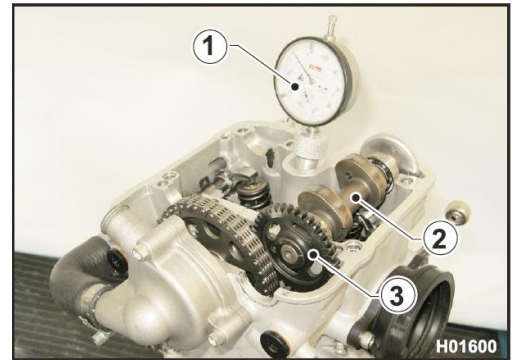
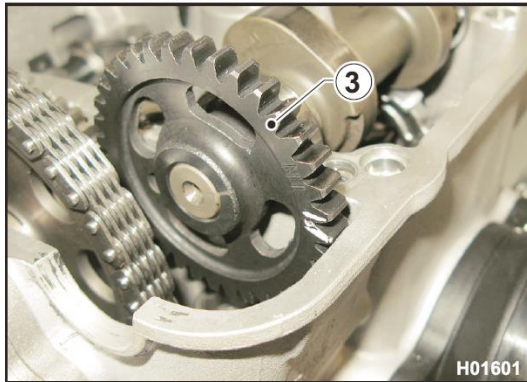

- Install the exhaust camshaft (5) lining up the dot on gear (6) with the head mating face.
- Make sure the dot on the inboard side of gear (6) is lined up with the dot on the right of the timing gear (4).
- Refit the oil pipe (7) with the curved end (7a) at the intake camshaft end.
- Lubricate lobes, springs and rocker arms with engine oil.
- Make sure that the centring bushings are in place in the caps.

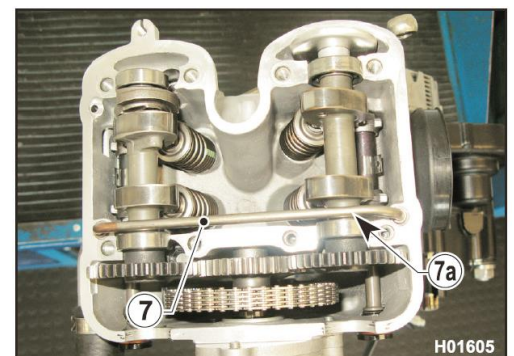
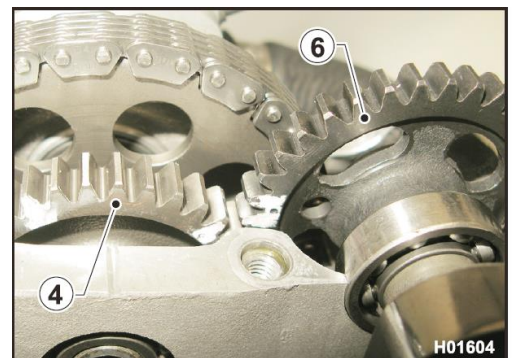

- Refit the camshaft caps (8) and tighten the screws (9) to 12 Nm (1.2 Kgm or 8.85 ft/lb) as marked on removal.

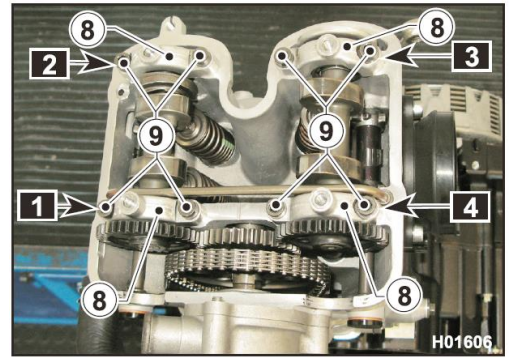

- Turn the crankshaft manually a few turns to check for free, smooth rotation without any tight points, then bring it back to Top Dead Centre position.

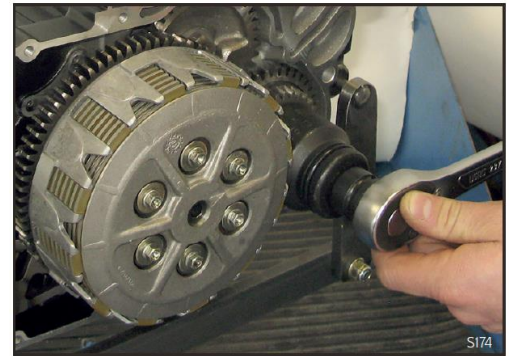

- Use a feeler gauge (10) to check clearance between rocker arm and shim.

**Valve Clearance table (when engine cold)**

Intake Side	0.10 mm - 0.15 mm
Exhaust Side	0.15 mm - 0.20 mm

- If clearance is not as specified, release the spring spacer using a hook, push aside rocker arm (11) and change the shim (12).

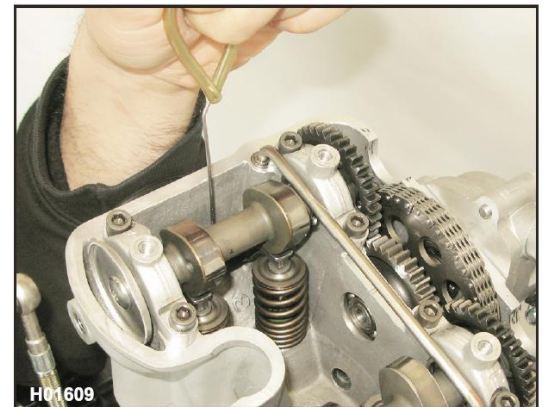

- Replacement shims are available in a 1.60 mm (0.063 in.) to 2.60 mm (0.1024 in.) thickness range, in 0.05 mm (0.002 in.) increments.

- Thickness (S) of the new shim is determined as follows:

- **S= (G1-G)+S1**
  - S= Thickness of new shim
  - G1= Measured valve clearance
  - G= Specified valve clearance
  - S1= Thickness of old shim

- On assembly, check valve clearances.

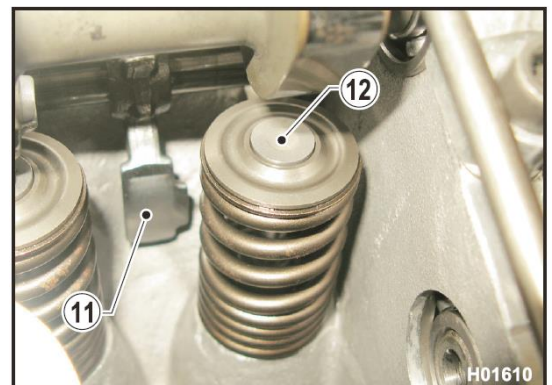



## Cylinder head cover and spark plug installation

- Smear Arexons 5552 compound on the half-round cut-outs (1).
- Refit head cover (2) and tighten the screws (3), in a cross pattern, to 8 Nm (0.8 Kgm or 5.8 ft/lb).
- Refit the lubrication pipe to the head (4) and tighten the drilled bolt (5) to 8 Nm (0.8 Kgm or 5.90 ft/lb).
- Refit the Spark plug (6); 10-12 Nm (1.0-1.2 Kgm or 7.2-8.9 ft/lb).

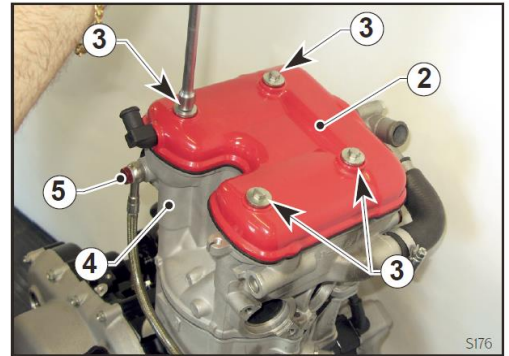

## Flywheel and flywheel cover installation

- Install the stator (1) with its mark lined up with the flywheel cover mark and tighten the three retaining screws (2) to 8 Nm (0.8 Kgm or 5.9 ft/lb) + Loctite 272.
- Insert the cable guide (3) into its seat in the cover and tighten the two retaining screws (4) of the pick-up sensor (5) with its plate to 3 Nm (0.3 Kgm or 2.21 ft/lb) + Loctite 272.

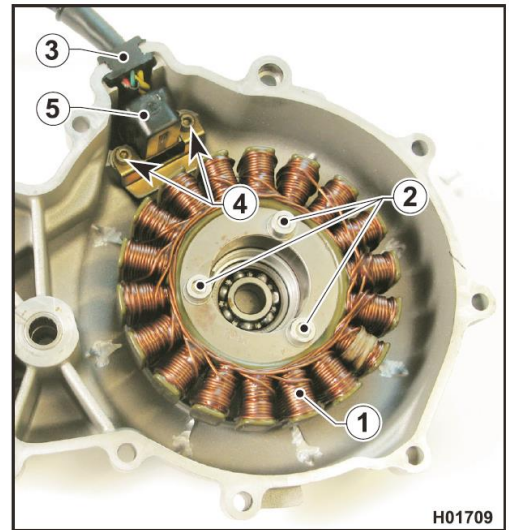

- Make sure the two centring bushings (6) are in place.

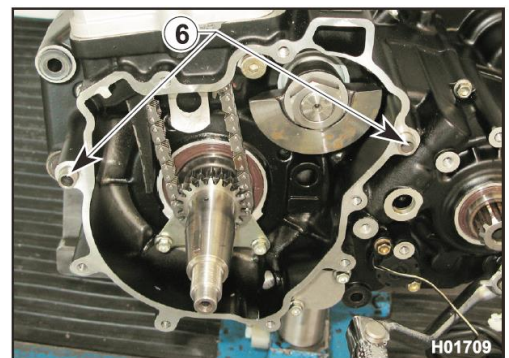

- Fit the gasket to the crankcase, locate the starter motor (7) to its flange (8) and install on the crankcase.
- Make sure the two locating bushings (9) are positioned correctly.
- Fit washer (10) and roller cage (11) to the crankshaft.

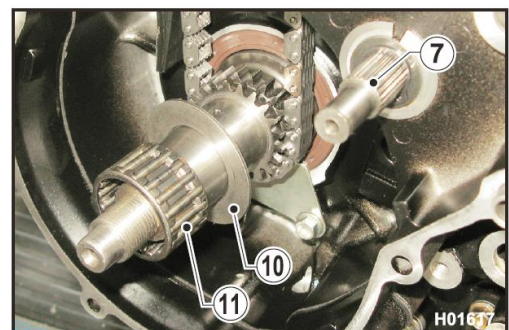
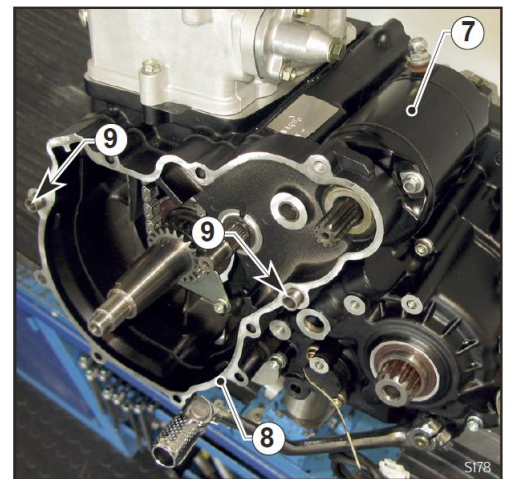

- Fit the free-wheel gear (12) to the flywheel (13) and tighten the screws (14).
- Degrease crankshaft taper end and flywheel bore and smear crankshaft taper end with Loctite 270.

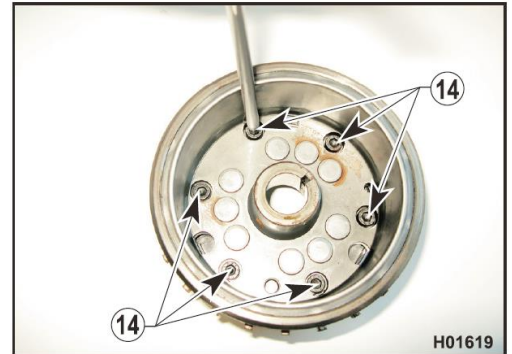
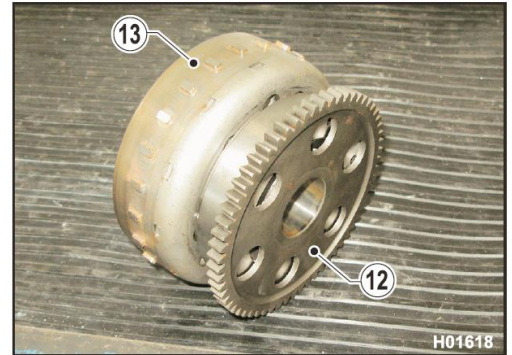

- Install flywheel (13) together with drive gear (14).

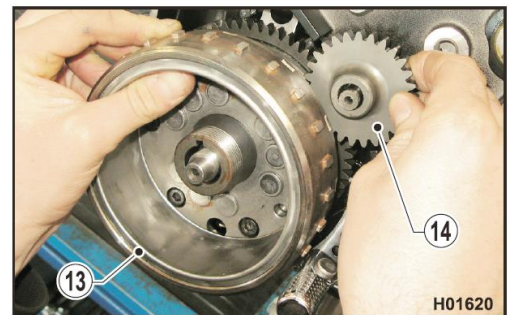

- Fit washer (15) and nut (16) and tighten to 130 Nm (13.0 Kgm or 95.89 ft/lb) fitting a dummy gear to the crankshaft gears at the opposite end.

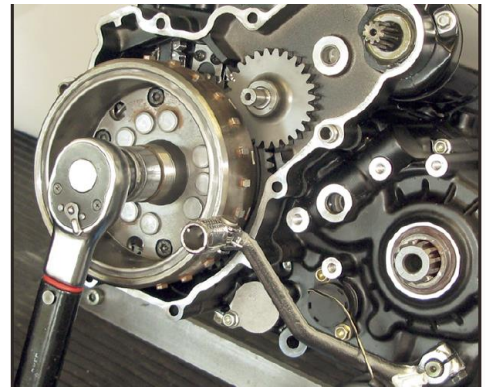
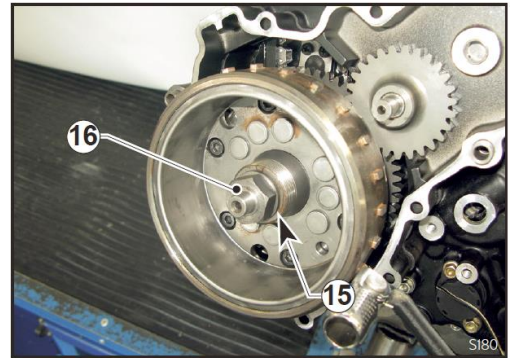

- Fit bushing (17) and starter motor drive gear (18).

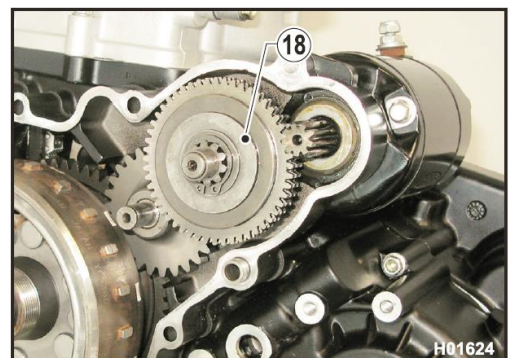
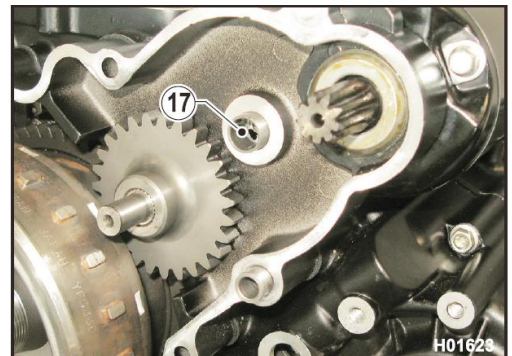

- Install gasket and cover (19) and tighten the screws (20) in a cross pattern

**WARNING**

The two longer screws (20a) and (20b) (L=65mm) must be refitted in their original positions.

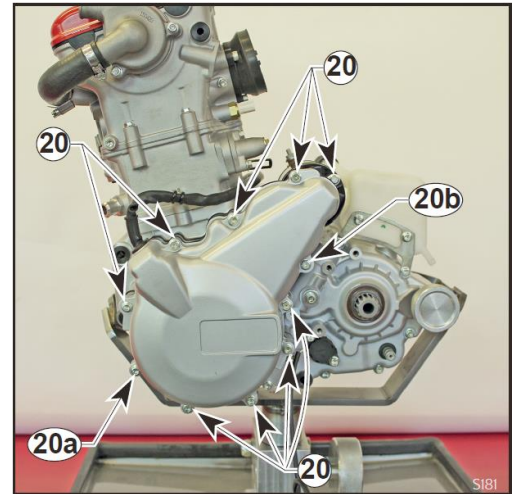

- Secure starter motor (7) tightening screw (21). 8 mm (0.31 in.) wrench

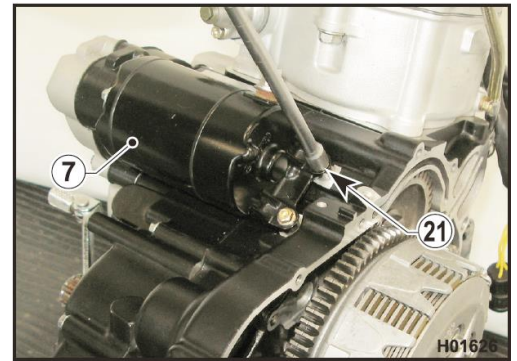

## Sprocket installation

- Fit the sprocket (1) and its circlip (2).

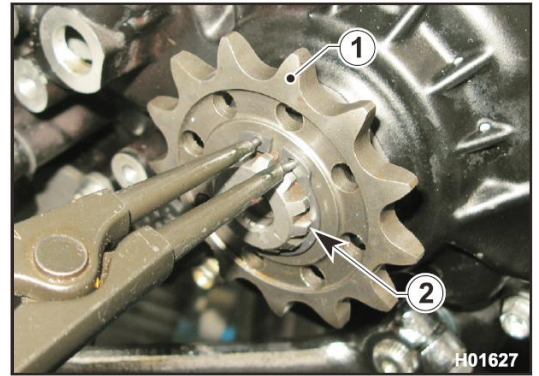

## Oil pump and filter cartridge assembly

- Assemble oil pump components in the order shown.

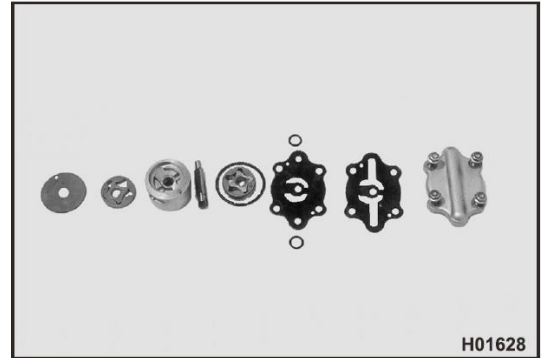

- Secure the cover using the four screws (1) up to 9 Nm (0.9 Kgm or 6.5 ft/lb).
- Refit the filter cartridge (2) and secure the cover using the two screws up to 9 Nm (0.9 Kgm or 6.5 ft/lb).
- Fit a new gasket and install the complete cover (3) using the thirteen retaining screws up to 9 Nm (0.9 Kgm or 6.5 ft/lb).

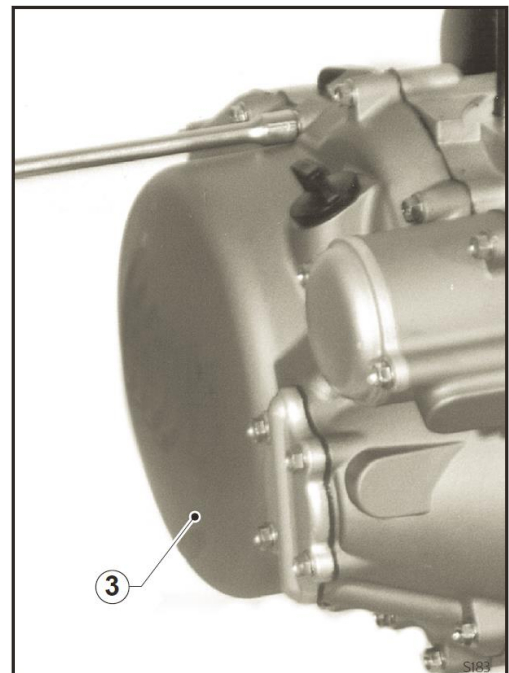
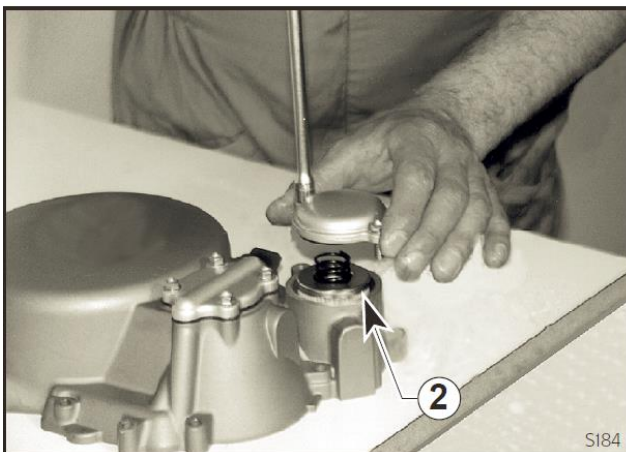
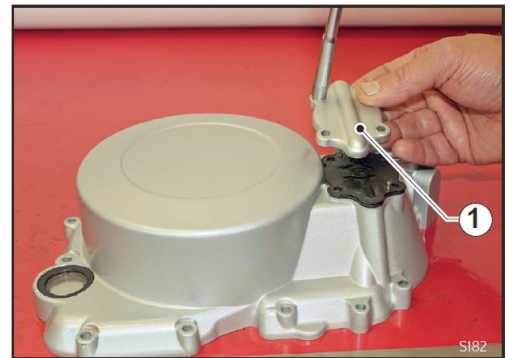

## Right crankcase assembly

- Fit the mesh filter (1) with the perforated end facing outwards
- Fit the two locating bushings (2) into the crankcase.

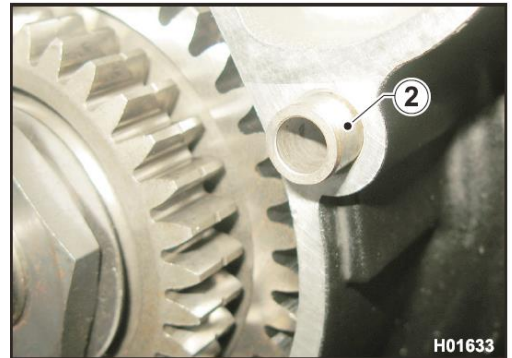
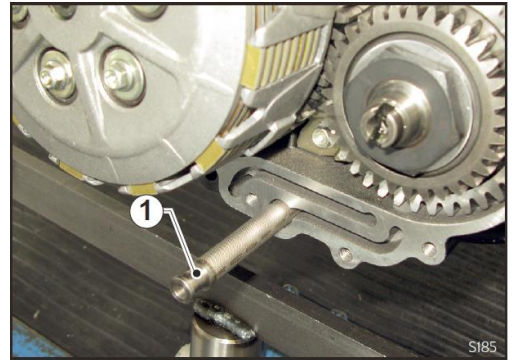
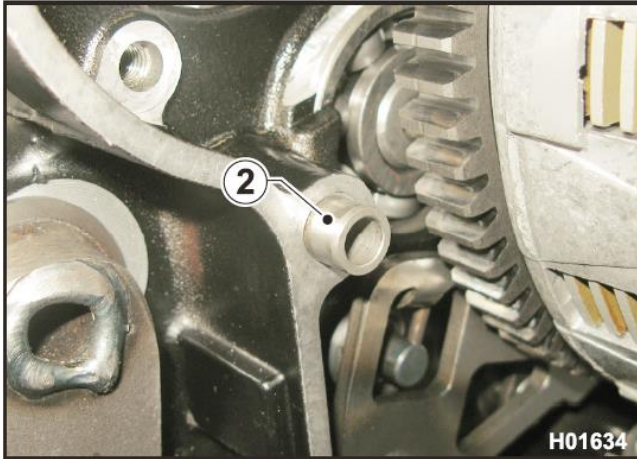

- Refit the gasket (3).
- Refit the cover (4) making sure to mate pump shaft (5) with the slotted end (6) of the output shaft (gently rock the sprocket to facilitate installation).

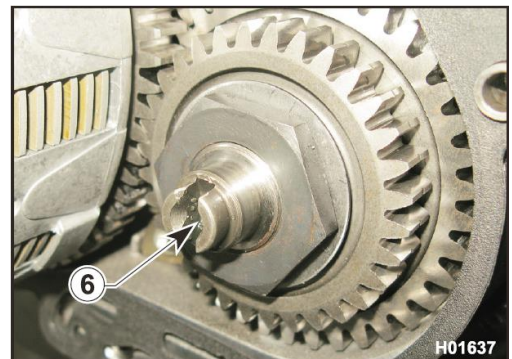
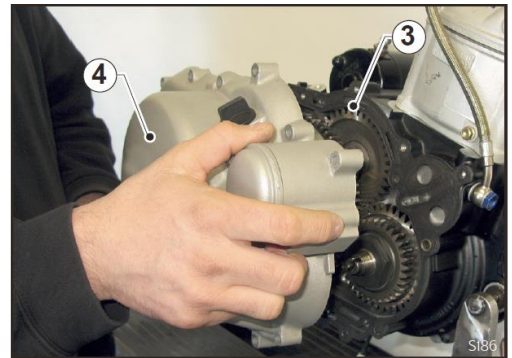
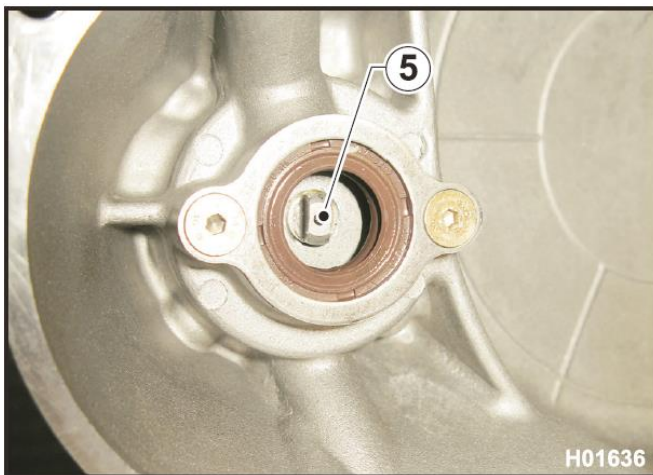

- Tighten the screws (7) in a cross pattern

Note: Screws (7) are not all the same length; make sure to refit them in their original positions.



# Chapter E.

---

## Bolts and Screws tightening torque



## GENERAL INFORMATION

- Tighten all nuts and screws to the specified torque using a torque wrench.
- If not tightened securely, a nut or a screw might become damaged or work itself loose, causing damage to motorcycle and injury to rider.
- An over tightened nut or screw might become damaged, its thread might strip, or the nut/screw might fail and work itself loose.
- Listed in the table are the tightening torque figures for the most important nuts and screws, which have determined in accordance with thread diameter, pitch and specific application.
- These figures are obtained after cleaning the threads with solvent.
- Tightening torque figures (+/- 5%).

## ENGINE

### Cylinder-Head

Reference	Description	Size	Ultimate Strength	Torque settings		Obs.
			MPa	Nm	kgm	
Z00054700	Head fastening screw	M8 x 1.25	590 - 785	15	1.5	-
800091589	Fastening nut cylinder-head	M10 x 1.5	800	37 + 90°	3.8 + 90°	Molykote HSC
8A0085071	Camshaft holder screw	M6 x 1	1200	12	1.2	Loctite n°243
800099711	Rocker arm pin plug	M14 x 1.5	560	25	2.55	Loctite n°243
800091587	Head cover fastening crew	M6 x 1	800	8	0.8	Loctite n°243
80A0A0574	Hose dilled fastening screw	M10 x 1	500	15	1.5	
800063885	Union pipe	M14 x 1.5	330	25	2.55	Loctite n°542
8000A6736	Water temperature sensor	M10 x 1.25	-	15	1.5	PTFE tape
ZD0067997	Canister screw	M5 x 0.8	800	5	0.5	Loctite n°243

### Crank gear

Reference	Description	Size	Ultimate Strength	Torque settings		Obs.
			MPa	Nm	kgm	
800071031	Ground nut	M18 x 1.25	870 - 1140	70	7.2	
800003170	Countershaft gear nut	M16 x 1.25	600	70	7.2	
800047871	Hexagonal screw	M8 x 1.25	800	11	1.12	Loctite n°243

### Transmission

Reference	Description	Size	Ultimate Strength	Torque settings		Obs.
			MPa	Nm	kgm	
800086006	Driving gear fastening nut	M24 x 1.25	870 - 1140	100	10.2	Loctite n°243

### Distribution

Reference	Description	Size	Ultimate Strength	Torque settings		Obs.
			MPa	Nm	kgm	
Z00055699	Centrifugal disc screw	M6 x 1	800	8	0.8	Loctite n°243
161535902	Slider fastening screw	M8 x 1.25	800	12	1.23	
Z00062728	Seal plug for tensioner spring	M6 x 1	-	5	0.5	

1 Nm = 0.73756 ft/lb

## Base

Reference	Description	Size	Ultimate Strength	Torque settings		Obs.
			MPa	Nm	kgm	
60ND02866	Oil valve plate screw	M4 x 0.7	500	3	0.3	Loctite n°243
Z00062725	Oil seal plate screw	M6 x 1	800	9	0.92	Loctite n°243
8000496608	Seal ring block screw	M5 x 0.8	1040	6	0.61	Loctite n°243
Z00042643	Primary shaft bearing plate screw	M6 x 1	800	9	0.92	Loctite n°243
ZA0066525	Bearing plate screw	M5 x 0.8	800	8	0.8	Loctite n°243
ZA0067997	Oil seal plate screw	M5 x 0.8	800	8	0.8	

## Lubrication System

Reference	Description	Size	Ultimate Strength	Torque settings		Obs.
			MPa	Nm	kgm	
800075415	Drain oil plug	M14 x 1.5	500	24	2.45	
800096747	Drain oil plug	M22 x 1.5	330	30	3.0	

## Electrical System

Reference	Description	Size	Ultimate Strength	Torque settings		Obs.
			MPa	Nm	kgm	
800049004	Flywheel nut	M16 x 1.25	835 - 1130	130	13.2	
60N102511	Stator screw	M6 x 1	800	8	0.8	Loctite n°270
8000A0573	Spark Plug	M10 x 1	-	12	1.23	Molykote <b>HSC</b>
60N102461	Pick-up screw	M4 x 0.7	800	3	0.3	Loctite n°272
8A0078674	Rotor ring screw	M6 x 1	1040	20	2	Loctite n°270

## Clutch

Reference	Description	Size	Ultimate Strength	Torque settings		Obs.
			MPa	Nm	kgm	
800036856	Hub and housing nut	M18 x 1	835 - 1130	61.7	6.3	

1 Nm = 0.73756 ft/lb

## Gear shift control

Reference	Description	Size	Ultimate Strength	Torque settings		Obs.
			MPa	Nm	kgm	
Y00028327	Release plate screw	M6 x 1	1040	10	1.02	
800071011	Gearshift sprocket screw	M8 x 1.25	800	28	2.85	Loctite n°243
8B0054139	Click fastening screw	M6 x 1	780 - 980	9	0.92	Loctite n°243
8C0067997	Gear sensor screw	M5 x 0.8	800	8	0.8	Loctite n°243

## Cooling System

Reference	Description	Size	Ultimate Strength	Torque settings		Obs.
			MPa	Nm	kgm	
Z00056443	Water rotor pump nut	M5 x 0.8	600	6	0.6	Loctite n°243
Z00062730	Water pump body screw	M6 x 1	800	8	0.8	Loctite n°542

If not otherwise specified, the tightening torques is as followed:

Size	Ultimate Strength	Torque settings $\pm 5\%$	
	MPa	Nm	kgm
M5 x 0.8	800	6	0.6
M6 x 1	800	8	0.8
M8 x 1.25	800	25	2.55

1 Nm = 0.73756 ft/lb

NOTE: Unless otherwise specified, standard torque values for the different thread sizes are as follows (+/- 5%)

Situation	Dimension	Tightening Torque		
		Nm	Kgm	ft/lb
Steel screws on plastic, with metal spacers	M4	2	0.2	1.45
Steel screws on brass, copper, aluminum	M4	2	0.2	1.45
Steel screws on iron, steel	M4	3	0.3	2.2
Steel screws on plastic, with metal spacers	M5	4	0.4	3
Steel screws on brass, copper, aluminum	M5	4	0.4	3
Steel screws on iron, steel	M5	6	0.6	4.4
Steel screws on plastic, with metal spacers	M6	6.5	0.65	4.8
Steel screws on brass, copper, aluminum	M6	6.5	0.65	4.8
Steel screws on iron, steel	M6	10.5	1	7.7
Steel screws on brass, copper, aluminum	M8	16	1.6	11.8
Steel screws on iron, steel	M8	26	2.6	19.1
Steel screws on iron, steel	M10	52	5	38.3
Steel screws on iron, steel	M12	100	10	73.8
Steel screws on iron, steel	M14	145	14.5	107



[www.ajpmotos.com](http://www.ajpmotos.com)